

VENTING

WALL MOUNTED SPLIT-TYPE AIR CONDITIONERS

SERVICE MANUAL

No.200303

Models

VAC-09CHSA/XA21 PLUS

VAC-12CHSA/XA21 PLUS

VAC-18CHSA/XA21 PLUS

VAC-24CHSA/XA21 PLUS

CONTENTS

- 1. IMPORTANT NOTICE**
- 2. PRODUCT DIMENSIONS**
- 3. REFRIGERATION CYCLE DIAGRAM**
- 4. OPERATION DETAILS**
- 5. WIRING DIAGRAM**
- 6. EXPLOSION VIEW AND PART LISTS**
- 7. PRECAUTION**
- 8. NAMES OF PARTS**
- 9. INSTALLATION**
- 10. TROUBLE SHOOTING**

1. IMPORTANT NOTICE

This service manual is intended for use by individuals possessing adequate backgrounds of electrical, electronic and mechanical experience. Any attempt to repair the appliance may result in personal injury and property damage. The manufacturer or seller cannot be responsible for the interpretation of this information, nor can it assume any liability in connection with its use.

The information, specifications and parameters are subject to change due to technical modification or improvement without any prior notice. The accurate specifications are presented on the nameplate label.

How to order spare parts

To have your order filled promptly and correctly, please furnish the following information:

Model No. with Indoor or Outdoor

Part No. in the Explosion View

Part Name

The quantity you ordered

2. Product Dimensions

Indoor Unit:



Outdoor Unit:

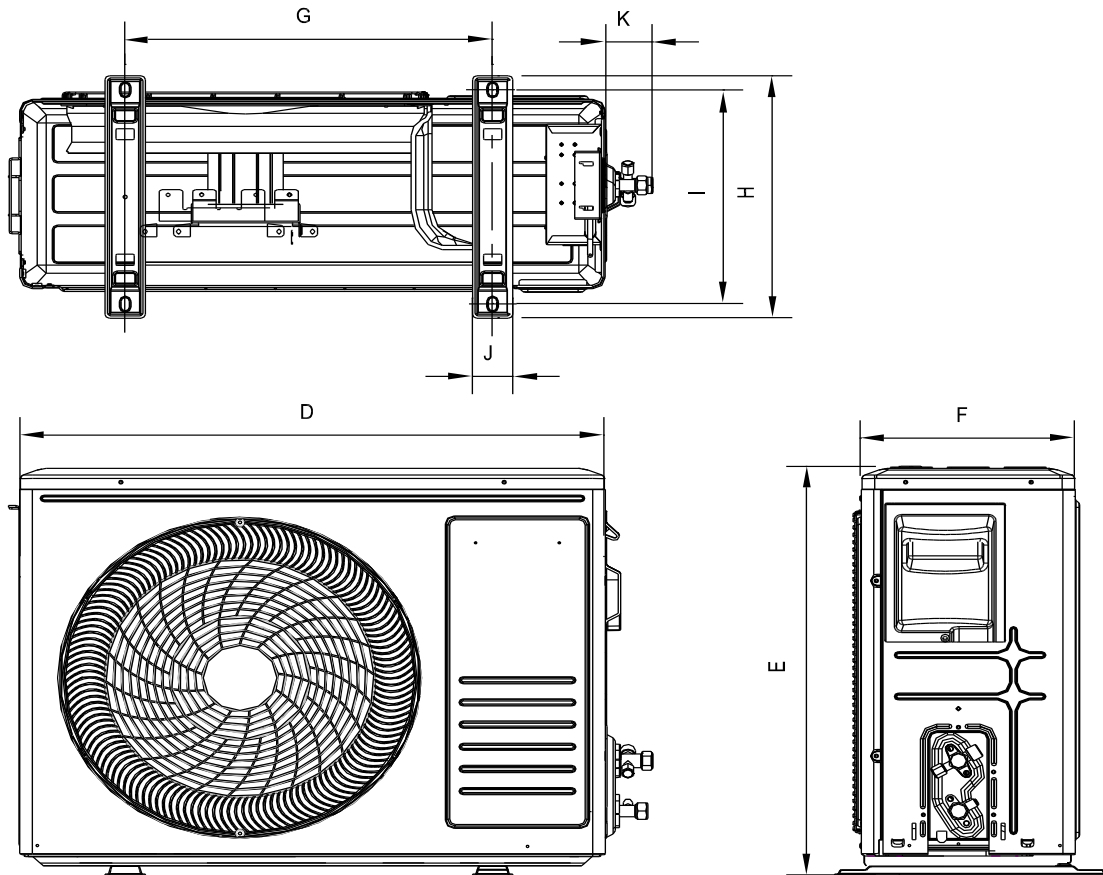

Model	Indoor unit					Outdoor unit					
	A	B	C	D	E	F	G	H	I	J	K
VAC-09CHSA/XA21 PLUS	698	255	190	600	500	230	375	276	256	52	55
VAC-12CHSA/XA21 PLUS	777	250	205	700	550	256	439.2	302	277.8	48	55
VAC-18CHSA/XA21 PLUS	910	292	205	760	550	256	508	302	277.8	48	55
VAC-24CHSA/XA21 PLUS	1010	315	220	900	650	315	623	399	349	65	63

3. Refrigeration cycle diagram

Cooling only

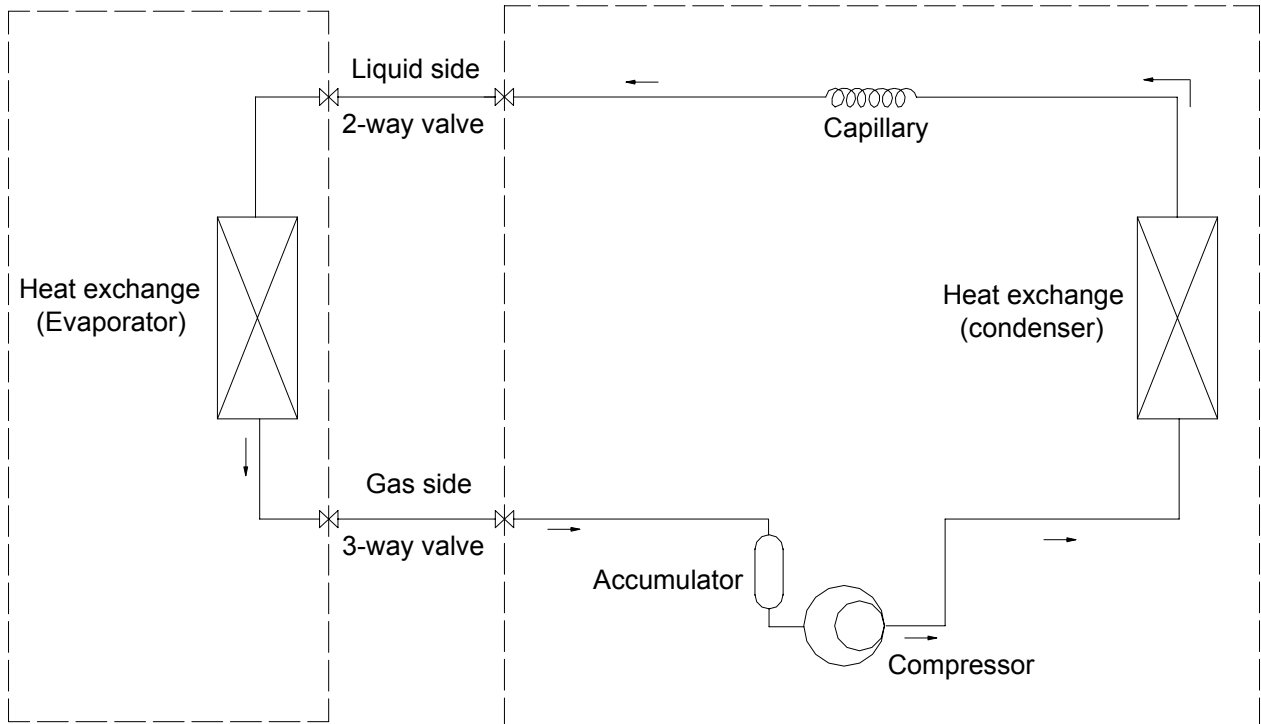

Heat pump

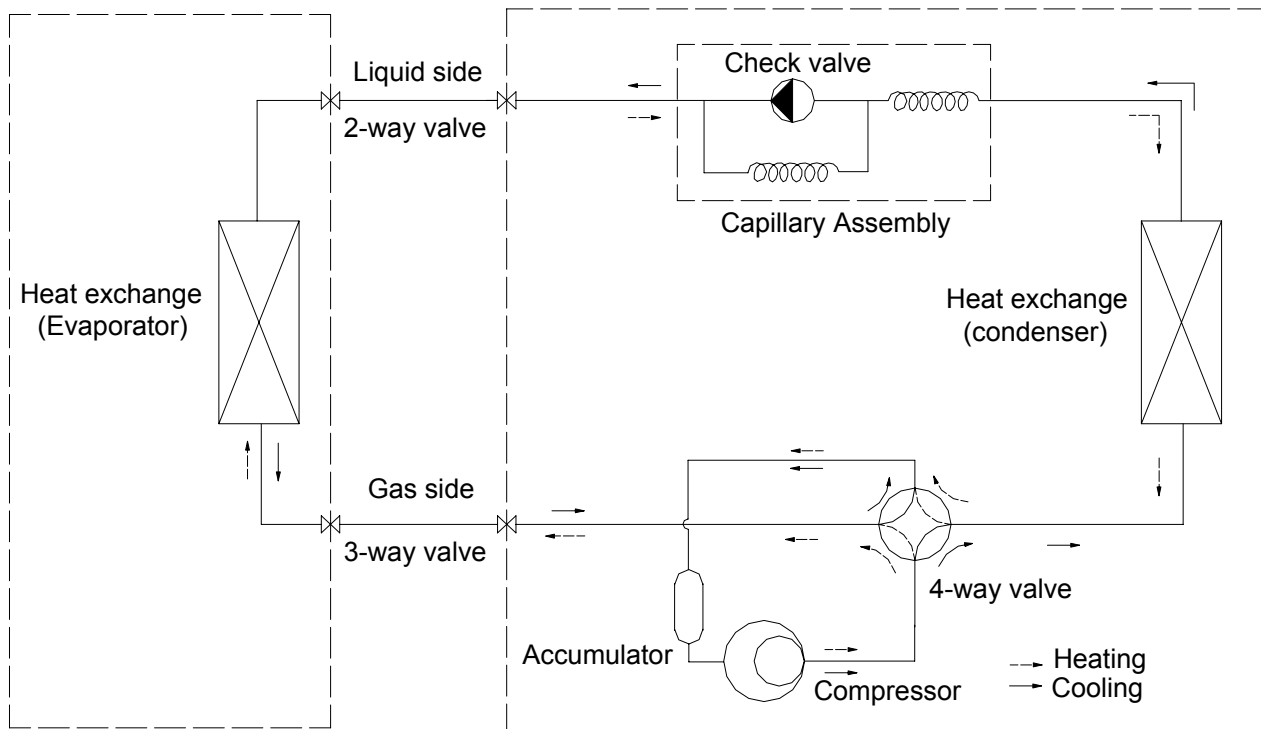

4. Operation Details

Remote controller

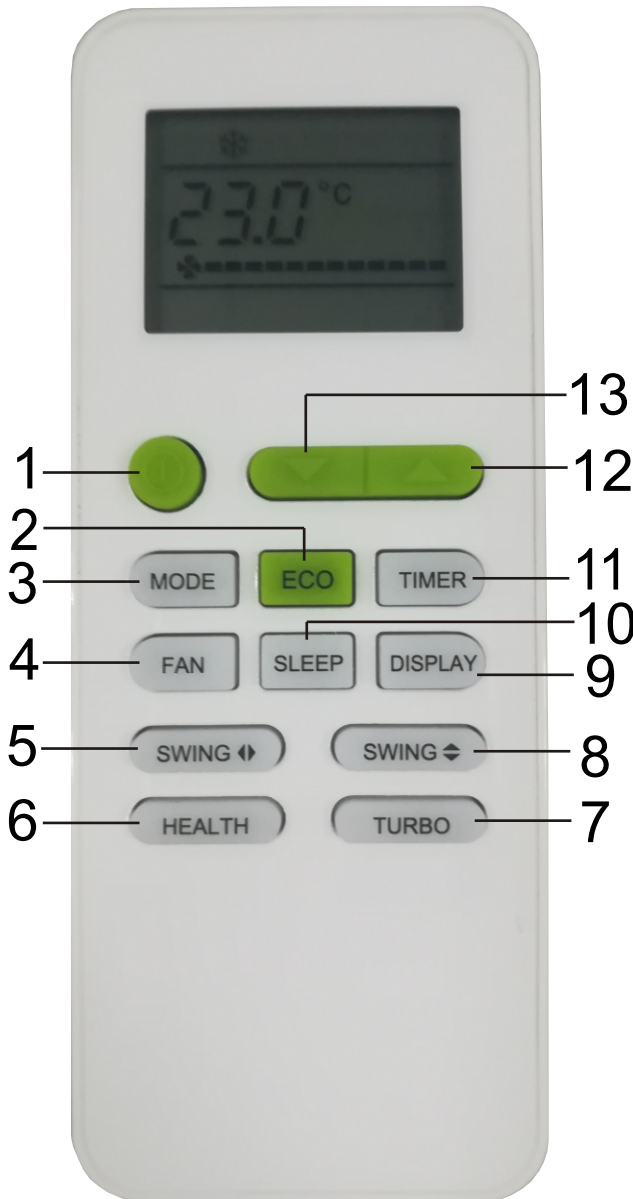

- 1 ON/OFF button**
To switch the conditioner on and off.
- 2 ECO button**
In cooling mode, press this button, the temperature will increase 2°C on the base of setting temperature:
In heating mode, press this button, the temperature will decrease 2°C on the base of setting temperature.
- 3 MODE button**
To select the mode of operation.
- 4 FAN SPEED button**
To select the fan speed of auto/low/mid/high.
- 5 SWING button**
To activate or deactivate of the movement of the “DEFLECTORS”.
- 6 HEALTH button**
To switch - on /off HEALTHY function. It is a button which controls the ionizer or plasma generator only for inverter type.
- 7 TURBO button**
In cooling mode, press this button, the unit will give the maximum cooling temperature with 16°C
In heating mode, press this button, the unit will give the maximum heating temperature with 31°C.
- 8 SWING button**
To activate or deactivate of the movement of the “DEFLECTORS”.
- 9 DISPLAY button**
To switch on/off the LED display (if present)
- 10 SLEEP button**
To activate the function “SLEEP”.
- 11 TIMER button**
To set automatic switching-on/off.
- 12 TEMP UP button**
Increase the temperature or time by 1 unit.
- 13 TEMP DOWN button**
Decrease the temperature or time by 1 unit.

Note: Each mode and relevant function will be further specified in following pages.

Remote Control

The remote controller is not presetting as Cooling Only Air Conditioner or Heat Pump by manufacturer.

Each time after the remote controller replace batteries or is energized, the arrowhead will flashes on the front of “Heat” or “Cool” on LCD of the remote controller.

User can preset the remote controller type depending on the air conditioner type you have purchased as follows:

Press any button when the arrowhead flashes on the front of “Cool”, Cooling Only is set.

Press any button when the arrowhead flashes on the front of “Heat”, Heat Pump is set.

If you don't press any button within 10 seconds, the remote controller is preset as Heat Pump automatically.

Note :

If the air conditioner you purchased is a Cooling Only one, but you preset the remote controller as Heat Pump, it doesn't bring any matter. But if the air conditioner you purchased is a Heat Pump one, and you preset the remote controller as Cooling Only, then you CAN NOT preset the Heating operation with the remote controller.

Electronic controller

NOTES:

- RT**-----Room Temperature.
IPT-----Indoor Pipe Temperature.
ST-----indoor Setting Temperature.
OPT---Outdoor Pipe Temperature.
CRT---Compensated Room Temperature

1. Automatic mode

1) The initial RT determines A/C working mode and the setting temperature (ST), the mode is determined effective only once unless A/C shut-down and then re-started. If from other mode switches to automatic mode (including mode conversion after shutdown), it should be that the compress stop more than 3 min then temperature judgment and automatic mode are conducted (it can conduct immediately from fan mode switched to automatic, the indoor fan stops, three minutes later the response is made and start up). Within 3 min, the output as: Showing the room temperature, indoor fans starts (or anti-cold airflow), the outdoor fan stops;

With auto re-start controller, once being turned off or in case of an accidently power cut, the A/C is able to retain and restore the original mode when being turned on or the power supply is resumed, if the auto restart function activated. power-off after power-on; while if the auto restart function isn't activated, the A/C enters standby state.

Heat pump

Mode Initial	RT	Initial ST
Cooling	$RT \geq 26^{\circ}\text{C}$	23°C
Dry	$26^{\circ}\text{C} > RT \geq 20^{\circ}\text{C}$	7°C
Heating	$RT < 20^{\circ}\text{C}$	23°C

Cooling-only

Mode Initial	RT	Initial ST
Cooling	$RT \geq 26^{\circ}\text{C}$	23°C
Dry	$26^{\circ}\text{C} > RT \geq 20^{\circ}\text{C}$	7°C
Ventilating	$RT < 20^{\circ}\text{C}$	—

Under automatic mode (including from automatic converted into Dry mode), when A/C received the temperature UP or DOWN signals from the remote controller, the setting temperature (ST) adjusts correspondingly to the current room temperature plus or minus 1°C , the automatic regulating temperature range is $\pm 2^{\circ}\text{C}$.

2. Cooling mode

- 1) The control of the compressor
 - a. When $RT - ST \geq 1^{\circ}\text{C}$, the compressor is running.
 - b. When $RT - ST < -1^{\circ}\text{C}$, the compressor stops.
 - c. When $-1^{\circ}\text{C} \leq RT - ST < 1^{\circ}\text{C}$, the compressor keeps its original state.
- 2) Outdoor fan motor and the compressor run simultaneously (except for defrosting).
- 3) The control of indoor fan motor:
 - a. Indoor fan motor can operate by automatic, low, middle, or high airflow speed circularly.

b. Indoor fan motor automatic airflow speed control, it works as shown in Figure 1:

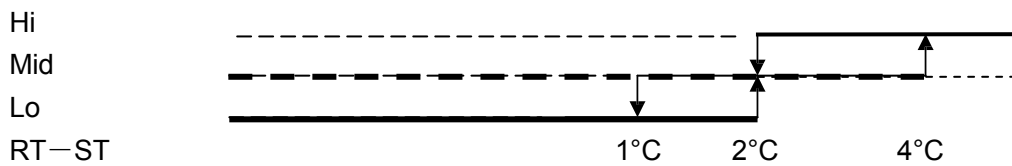

Figure 1 Cooling automatic airflow

When the temperature changing leads the fan speed variation, the switch can only be made orderly, and in every grade of air flow speed should run 1 minute at least.

3. Dry mode

While select to this mode, the air conditioner operates for 3 minutes according to cooling mode firstly (ST set at 7°C), and then takes the detected backflow air temperature minus 2°C as a new set temperature (*the lowest temperature: 5°C*) and runs according to cooling mode, indoor fan operates at low-speed, at this moment the setting operation of fan speed invalid but Swing adjustable.

4. Heating mode

On the Heating mode, the room temperature (RT) is compensated (CRT), after that, the room temperature displayed on the LED is $CRT = RT - 3^{\circ}\text{C}$.

- 1) The control of the compressor
 - a. When $ST - CRT \geq 1^{\circ}\text{C}$, the compressor is running.
 - b. When $ST - CRT < -1^{\circ}\text{C}$, the compressor stops.
 - c. When $-1^{\circ}\text{C} \leq ST - CRT < 1^{\circ}\text{C}$, the compressor keeps its original state
- 2) Outdoor fan motor and the compressor run simultaneously (except for defrosting)
- 3) The control of indoor fan motor:
 - a. Indoor fan motor can operate by automatic, low, middle, or high airflow speed circularly.
 - b. Indoor fan motor automatic airflow speed control, it works as shown in Figure 2:

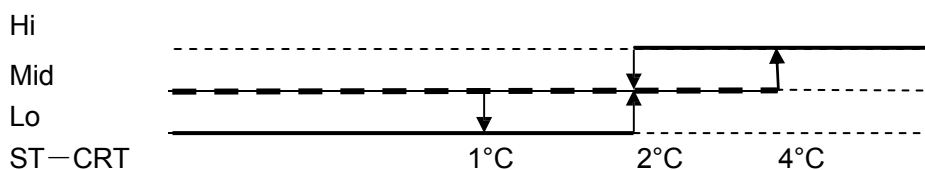

Figure 2 Heat automatic airflow

When the temperature changing leads the fan speed variation, the switch can only be made orderly, and every grade of air flow speed should run 1 minute at least.

- 4) Vane motor control: run as set state.
- 5) 4-way valve control:
 - a. Under heating mode, the four-way valve maintains well-connected status (including the compressor stops on set condition, except for the defrosting process)
 - b. When the mode switches into the heating mode or A/C start-up, four-way valves will open 5 Seconds before the compressor starts; while the mode exits from the heating mode or A/C turn off, the four-way valve will close 2min later after shut-down the compressor.

6) Defrosting function:

During defrosting, once mode changing, economic operation or temperature setting signals received, the buzzer and display will make response immediately, but the other operations won't implement until defrosting finished;

During defrosting, the signals of On-Off, Timing, Sleep, Fan speed and/or Swing can respond, but the Fan speed and/or Swing should be in accordance with operation for Cold Air Prevention.

Except the above signal processing during defrosting, no other signals will deal with, only a voice of buzz for response.

During defrosting, electrical heating (*optional function*) stops compulsively.

Defrosting Enter and Exit program:

Option 1: with jumper JC

The condition of enter defrosting: run into defrosting once any of condition 1, 2, and/or 3 met.

Condition 1: As shown in figure 3

Definition:

The following conditions a, b and c all required to meet:

- $IPT1$ settles for $IPT1 = IPT_{max} - \Delta IPT$
- $t_5 \geq 50\text{min}$ (running time $t_5 \geq 50\text{min}$ (the compressor runs cumulatively) t_5 is removable, and could be less than t_1)
- $IPT < 40^\circ\text{C}$, and lasts 2min.

Running into defrosting on condition 1, the first running time of set defrosting is F (8min); after running a defrosting cycle, the defrosting time should be determined and adjusted.

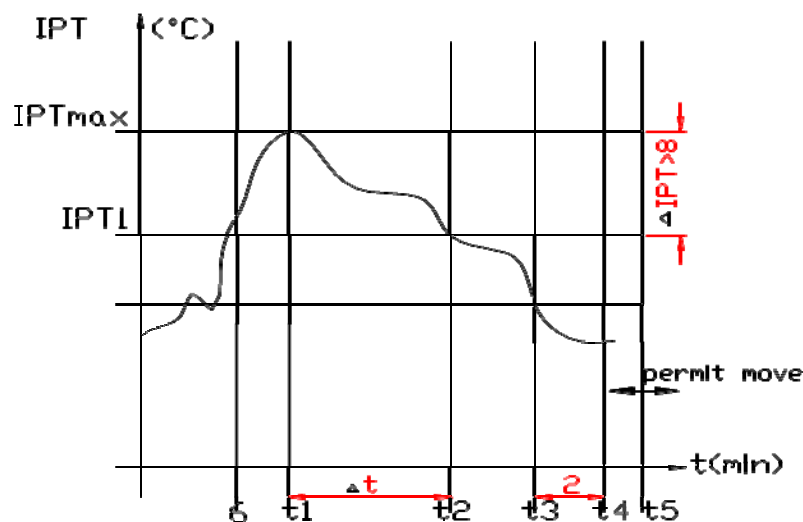

Figure 3

Condition 2: When running time is more than or equal to 120 min (compressor is running accumulatively), the indoor temperature is less than 35°C for 2 min sustained. Running into defrosting under condition 2, defrosting time set is 8 min.

Condition 3: After the compressor is operating for 20min continuously, the indoor pipe temperature is less than 23°C (cold air prevention wind temperature) when the fan stops running (including temperature dropping when compressor operating, not including the compressor's starting up course), and the machine runs into defrosting according to any one condition as below.

Running into defrosting under condition 3, defrosting time set is 10 min.

- a) Running into the first defrosting in 20 min after start-up.
- b) The interval from last defrosting equivalent to or more than 50 min (stopping the compressor or the machine in standby is allowed in the meantime).

Option 2: Without Jumper JC, and no OPT outdoor sensor

when the compressor runs for 45 min (accumulated), if the indoor coil temperature is less than 40°C for 2 min, the machine runs into defrosting, and lasts for 3min, otherwise when the compressor runs for 120 min (accumulated), the machine runs into defrosting automatically and last for 10 min.

Option 3: Without jumper JC, but with OPT outdoor sensor

While heating, when the temperature of condenser is lower than E °C (-4°C), and the compressor runs for 45 min (accumulated), then the machine runs into defrosting and lasts for 10 min.

Option 4. On heating, while the outdoor fan motor stopped but the compressor operated accumulative totally 30min, then the machine runs into defrosting and last for 8 min. if the accumulative totally less than 30min, but accord with one of the condition option 1-3 then the machine runs into defrosting at the option 1-3 and the accumulative total time restarts from 0.

Conditions for quitting defrosting

(1) The quitting conditions for option 1, option 2 and 4, the machine quits from defrosting if any one below condition met.

- a. Defrosting time is over.
- b. When it runs in defrosting for three minutes, the IPT indoor coil temperature rises 15°C or above from the bottom point.

(2) The quitting conditions for option 3.

When OPT ≥ 20°C or defrosting for more than 10 min, then quit from defrosting.

(3) Defrosting process shown in Figure 4

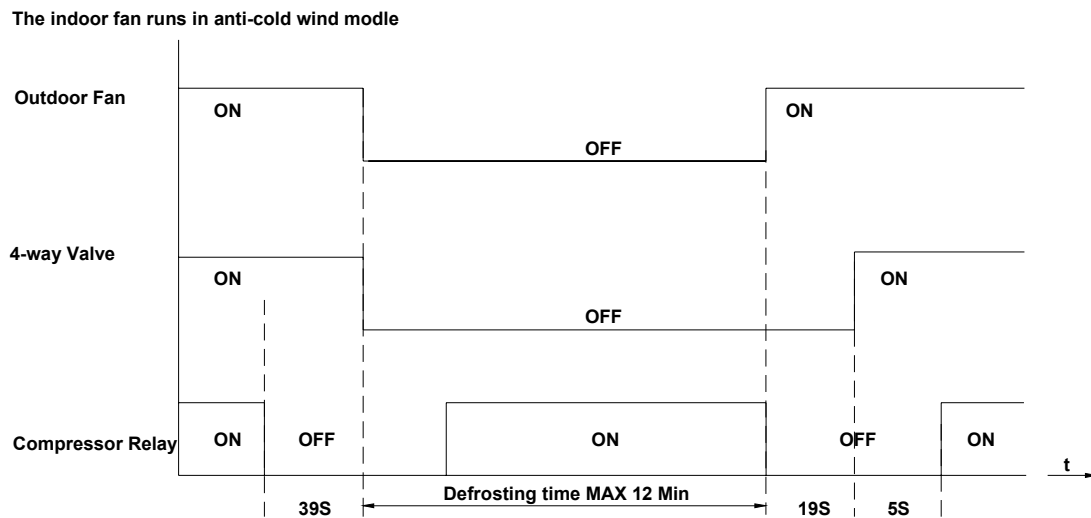

Figure 4 Defrosting process

7) Auxiliary electric heating function (optional)

(1) The default condition is automatic on/off the electric heating function.

(2) The conditions of auxiliary electric heating works (all the following conditions must be met)

- a. the compressor runs for more than 3min;
- b. indoor fan runs normally;
- c. not in defrosting state;

- d. auxiliary electric heating is turned off for more than 30s.
- e. $ST-RT \geq 0^{\circ}\text{C}$;
- f. $RT < 25^{\circ}\text{C}$;
- g. $IPT \leq 43^{\circ}\text{C}$;

(3) The conditions of stopping auxiliary electric heating (any one of the following conditions met, the state stops)

- a. the compressor stops
- b. $RT \geq 27^{\circ}\text{C}$;
- c. $IPT \geq 50^{\circ}\text{C}$
- d. indoor fan stops.
- e. running into sleeping function

5. Fan mode

- 1) Indoor fan motor is running at setting speed (the speed same as heating mode).
- 2) Vane motor control: running according to the setting condition.
- 3) The outdoor unit doesn't work under fan mode.

6. Sleeping mode

1) Under sleep mode, the indoor fan motor running at low speed, except the power light and sleep light are ON, timer lights ON/OFF according to the setting state, running light OFF. LED will be OFF after displaying 30S.

2) Temperature control:

(1) While changing from Cool mode to Sleep mode, one hour later, the operation Temp. = $ST + 1^{\circ}\text{C}$, another one hour later, the operation Temp. = $ST + 2^{\circ}\text{C}$, after then the temperature has no changed anymore.

(2) When changing from Heating mode to Sleep mode, one hour later, the operation Temp. = $ST - 1^{\circ}\text{C}$, another one hour later, the operation Temp. = $ST - 2^{\circ}\text{C}$, after then no changed anymore.

3) The machine will automatically shut up after running 10 hours under sleep mode.

When Timer ON and Sleep mode are implemented at the same time, the Sleep mode can not be functioned.

7. Timer function

The timer can preset between 10min to 24h, when the time set less than "10" hours, the displayed time shown by 0.5 hour as the unit, when the time set more than or equal to "10" hours, the displayed time shown by 1 hour as the unit.

8. Emergency switch (ON/OFF)

1) When stand-by, to operate by pressing the emergency switch as follows:

Press the emergency switch within 3 seconds, release emergency switch while the buzzer rings once, the machine goes into Cooling mode. If the buzzer rings twice while release emergency switch, Heating mode is selected. To press the Emergency switch while A/C is on, the buzzer rings once and then A/C will shut down.

2) The machine runs mandatorily as selected mode within 30min when Emergency operated, meanwhile indoor fan motor runs in high-speed, and stepping vane swinging as well. 30min later the A/C goes into automatic mode under the same operation manner, the set temperature to be 23°C , and the rotate speed of indoor fan motor automatic control, stepping vane swinging all the way.

3) To press the emergency button when the A/C goes on operation, then the machine runs into stand-by.

4) Under emergency operation, the function of compressor's time-delay protection, Anti-frosting protection in cooling mode, Overheating protection in heating mode, sensor fault protection and defrost operate are effective.

5) Under emergency operation, once effective signal from remote controller received, the A/C exits form of emergency mode without delay, and operates according to the setting value from remote controller immediately.

9. Auto -restart function

1) The PCB retains the setting parameters in case of power off. When the power supply is resumed, the machine, which has been started up the power-off memory function, is able to restore into the original running state automatically.

To press the emergency button and power on the unit, and hold on for 10 seconds, The buzzer

2) will ring **three times**, after this operation, the auto restart function activated.

3) To close auto restart function while it is activated, repeat process as above 2), the buzzer will ring four times.

10. Protection / Failure code

10.1 Protection

1) Compressor's protection:

a. The PCB which with Auto-restart function, once it is activated, the compressor goes along 3min delay protection when power on, otherwise the compressor without this protection even when the PCB is power-on.

b. The compressor's 3 min interval protection: the compressor can't start-up until it stops 3 min later. (*except for the defrosting process*).

c. . After the compressor started, it's operation state remains the same within 3 min even when ST, RT variation.

2) Anti-frosting protection of indoor evaporator (Cooling mode):

If $IPT \leq 0^{\circ}\text{C}$ detected in consecutive 3 min, compressor and outdoor fan motor to be stopped operation, indoor fan motor runs at high-speed forcibly; if $IPT \geq 5^{\circ}\text{C}$ detected 3min later, then outdoor fan motor and compressor will start up, and indoor fan motor restores to it's original state.

3) Overheating protection (Heating mode):

If $IPT \geq 55^{\circ}\text{C}$, the outdoor fan motor: OFF.

If $IPT \geq 65^{\circ}\text{C}$, the compressor: OFF, and indoor fan motor runs at high-speed forcibly.

When $IPT \leq 48^{\circ}\text{C}$, the outdoor fan motor and the compressor start up, indoor fan motor restores to it's original state.

4) Cold air prevention (Heating mode):

This function is intend to prevent cold air from being discharged when the heating operation starts or when defrosting.

a. When running into the heating mode, once the compressor fails to comply with the start-up conditions, the fan speed is regulated according to the coil temperature within 2 min, 2 min later the indoor fan motor stops. If the compressor starts up within 2 min, then operating according to Figure 5.

Under heating process, while the compressor stop (including stopping for protection), the fan motor's operation (including stopping the indoor fan motor) is regulated according to the coil temperature within 1min, 1min later the fan will be stopped forcibly.

b. When the indoor fan motor running at a low-speed under cold air prevention operation, once auxiliary electric heating works, the vane immediately withdraws from the cold air prevention location and turn back to normal vane angle. While auxiliary electric heating stops, indoor fan motor goes on to run at low-speed accordingly, the vane turns to cold air prevention location

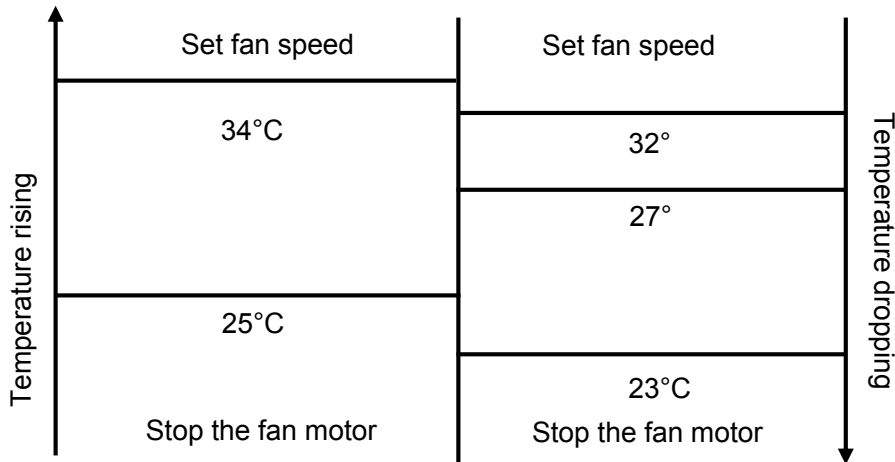

Figure 5 Cold air prevention

10.2 Failure code

The following table shows the fault protections.

When failures happens, the PCB alarms and buzzer rings three times, Failure code shows on display board, and the PCB operates protection procedures.

Failure code: For the machine with LED display (**88**), the code shows on LED, for machine without LED, the code reflects by the running light.

Failure	Running Light Flash	LED Display (88)
RT Sensor Failure	Once / cycle	E1
IPT Sensor Failure	Twice / cycle	E2
System Protection	4 times/cycle	E4
System Protection(high/low pressure protection model)	/	E5
Indoor Fan Motor Failure	6 times / cycle	E6

While failure happens, the code displayed statically, if there are several failure codes reported at the same time, then failure codes appears by turns every eight seconds correspondingly.

a. Sensor's failure protection: when the sensor tested temperature out of the range --- $50^{\circ}\text{C} \leq T \leq 110^{\circ}\text{C}$, sensor failure is determined.

Once RT and/or IPT sensor failure appears, the compressor stops, and indoor and outdoor fan motors shut off. Remote controller doesn't response to any signal except for shutdown. During failure the machine can run in fan mode. After the failure is settled, the PCB restores to standby status.

b. Failure protection of Indoor PG fan motor: If there is no feedback signal of rotated speed within 5s, the indoor fan motor stops, meanwhile, the compressor, outdoor fan motor, four-way valve and/or auxiliary electric heater etc. also cut down.

The indoor fan motor restarts again 10 seconds later, if still there is no feedback signal of rotated speed within 5 seconds, the A/C stops and goes into indoor fan motor failure protection, buzzer rings three times, and running light flashes at 6 times per 8 seconds. Once there is feedback signal while the failure recovery, the failure will relieve automatically.

5. Wiring diagram

MODEL: VAC-09CHSA/XA21 PLUS, VAC-12CHSA/XA21 PLUS, VAC-18CHSA/XA21 PLUS

INDOOR UNIT:

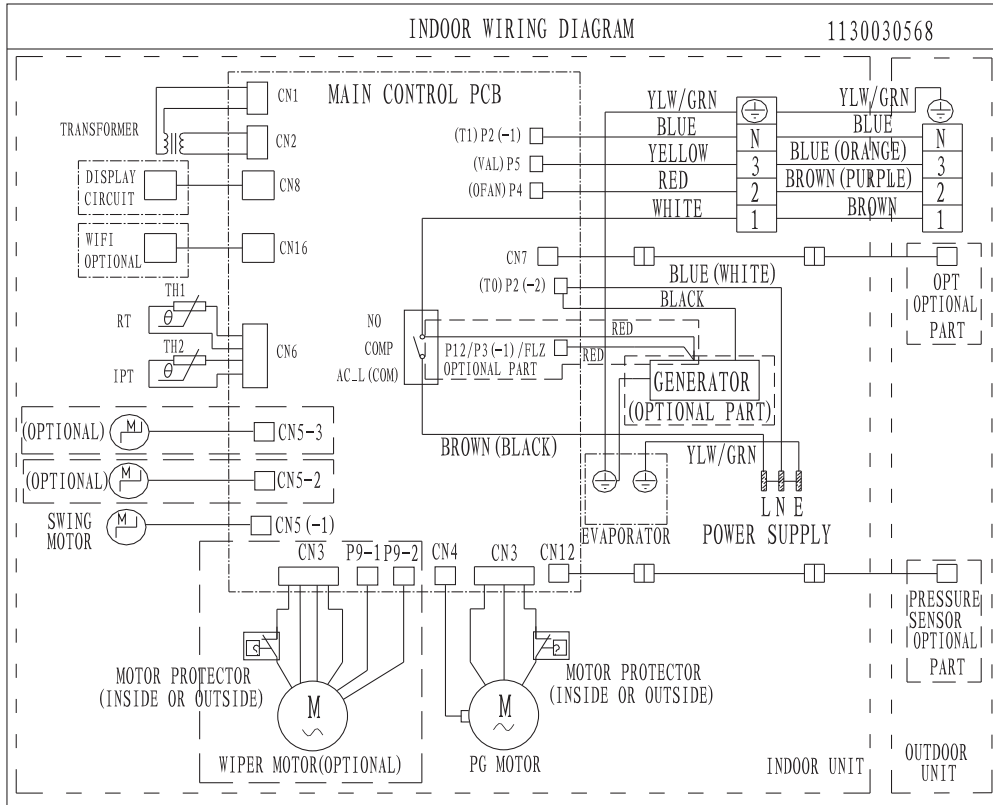

OUTDOOR UNIT

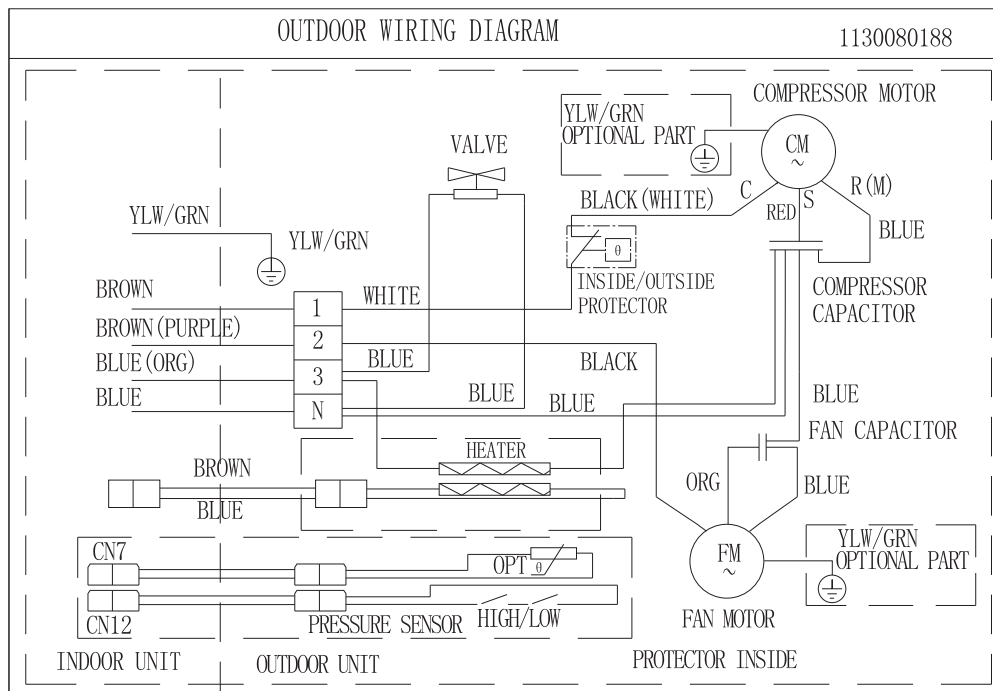

MODEL: VAC-24CHSA/XA21 PLUS
INDOOR UNIT

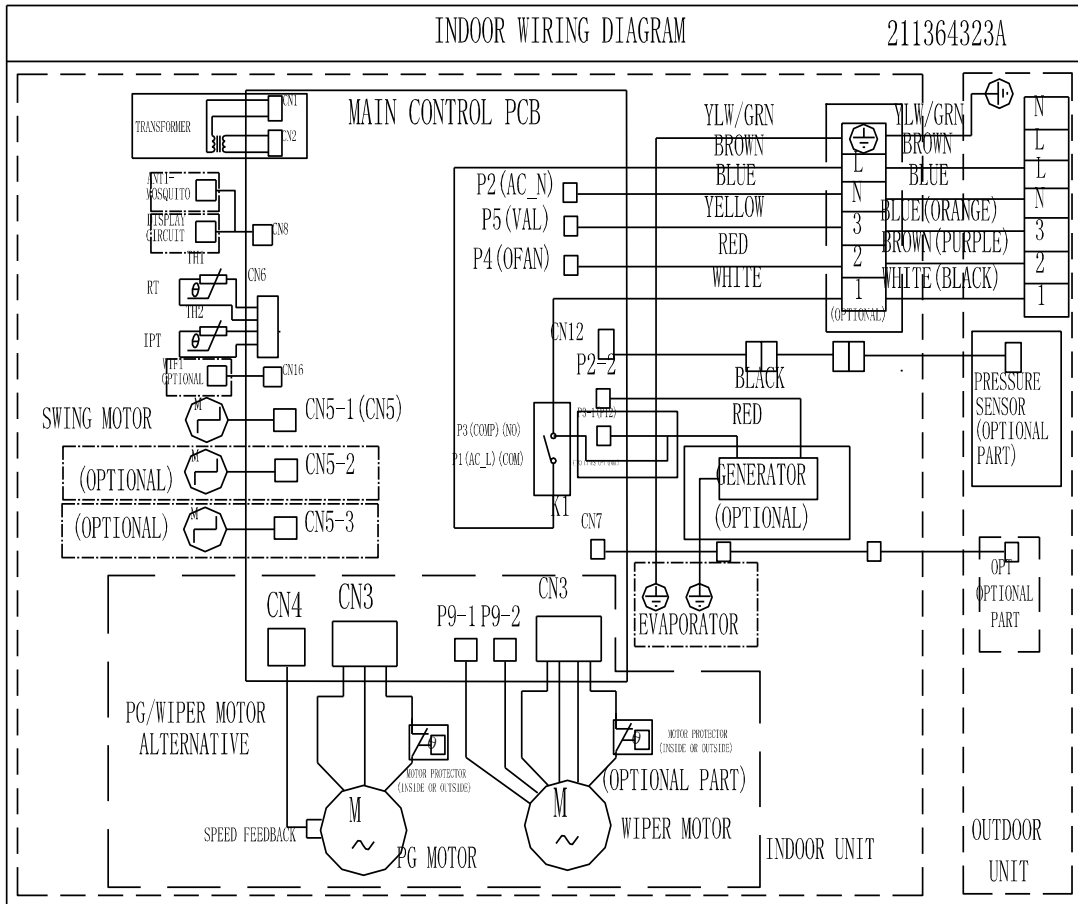

OUTDOOR UNIT

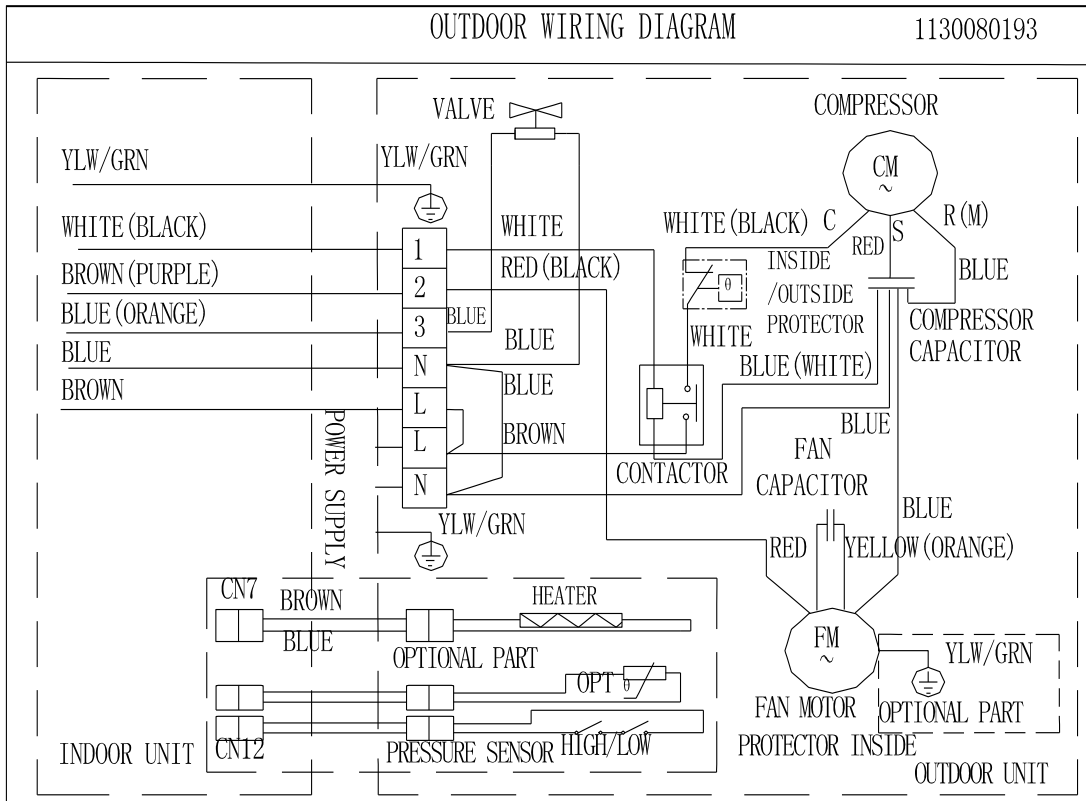

6. Explosion view and parts

Indoor Unit- VAC-09CHSA/XA21 PLUS

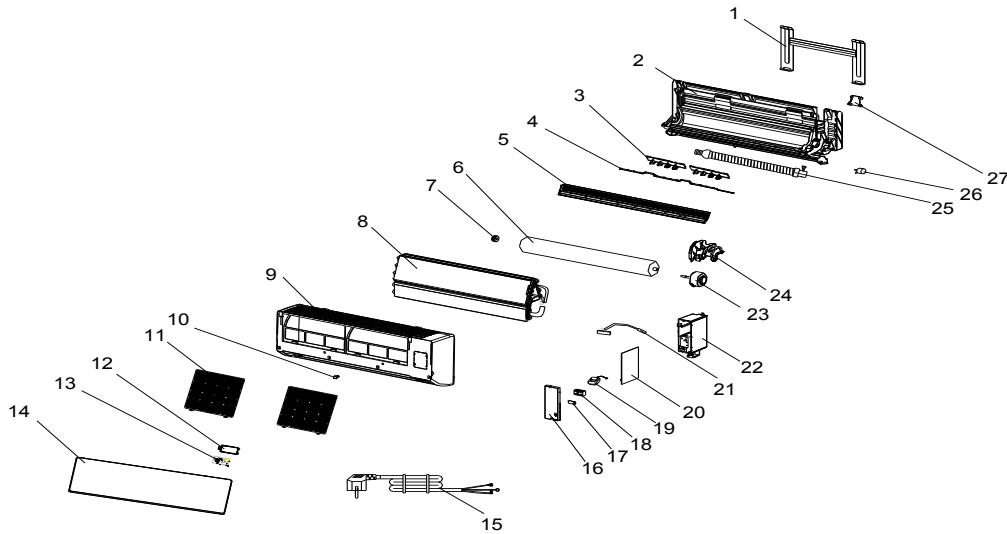

No.	Part No.	Part Name	Q'ty	Remark
1	41109-000042	Installation Plate	1	
2	41199-003278	Base	1	
3	41101-000042	Vertical Vane Assembly	2	
4	41101-000189	Vertical Vane Connector	1	
5	41103-000103	Vane	1	
6	42004-000040	Cross Fan	1	
7	42007-000001	Bearing Mount	1	
8	92011-002807	Evaporator	1	
9	41106-002347	Face Frame	1	
10	41108-000066	Screw Cover	1	
11	42008-000070	Air Filter	2	
12	42003-000001	Display PCB Box	1	
13	31102-000085	Display PCB	1	
14	41106-002092	Front Panel	1	
15	22007-000015	Power Supply Cord	1	
16	41105-000146	Electrical Box Cover	1	
17	42001-000103	Cable Clamp	1	
18	11304-100023	Terminal	1	
19	10502-100028	Transformer	1	
20	31101-000669	Main PCB	1	
21	41105-000104	Electrical Box	1	
22	10104-100014	Indoor Sensor Assembly	1	
23	22001-000265	Indoor Motor	1	
24	42003-000060	Indoor Motor Cover	1	
25	42009-000011	Drainage Hose	1	
26	22001-000313	Vane Motor	1	
27	41101-000242	In And Out Pipe Fixer	1	
28	22013-001969	Remote Controller	1	Not shown in Explosion view
29	A1101-007483	Indoor Carton	1	
30	A2006-000050	Left Foaming	1	
31	A2006-000030	Right Foaming	1	

Outdoor Unit-VAC-09CHSA/XA21 PLUS

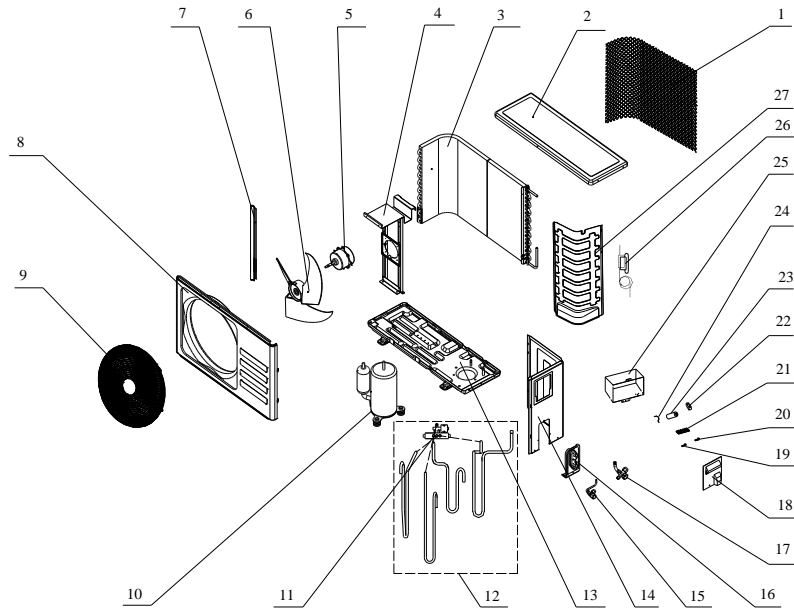

No.	Part No.	Part Name	Q'ty	Remark
1	42011-000108	Grille	1	Optional
2	41207-000017	Top Cover	1	
3	92011-000391	Condenser	1	
4	41203-000038	Outdoor Motor Supporter	1	
5	22001-000006	Outdoor Motor	1	
6	42004-000072	Propeller Fan	1	
7	41205-000126	Left Grille Supporter	1	
8	41206-000030	Front Plate	1	
9	42011-000068	Fan Guard	1	
10	92014-000323	Compressor And It Accessories	1	
11	92008-000177	4-way Valve	1	
12	92007-000816	4-way Valve Assembly	1	
13	41202-000060	Base	1	
14	41205-000056	Right Plate	1	
15	92008-000043	Two-way Valve	1	
16	41204-000012	Valve Supporter	1	
17	92008-000115	Three-way Valve	1	
18	41201-000004	Electrical Box Cover	1	
19	42001-000037	Cable Clamp(φ6)	1	
20	42001-000035	Cable Clamp(φ7)	1	
21	11304-100007	Terminal	1	
22	10303-100020	Fan Motor Capacitor	1	
23	22003-000005	Compressor Capacitor	1	
24	42001-000029	Capacitor Strip	1	
25	41214-000342	Electrical Parts Box	1	
26	92007-001918	Capillary Assembly	1	
27	41208-000118	Partition plate	1	
28	A2005-000494	Base Carton	1	Not shown in Explosion view
29	A1201-008091	Cabinet Carton	1	
30	A1202-000013	Base Foaming	1	
31	41213-000008	Cover Forming	1	

Indoor Unit- VAC-12CHSA/XA21 PLUS

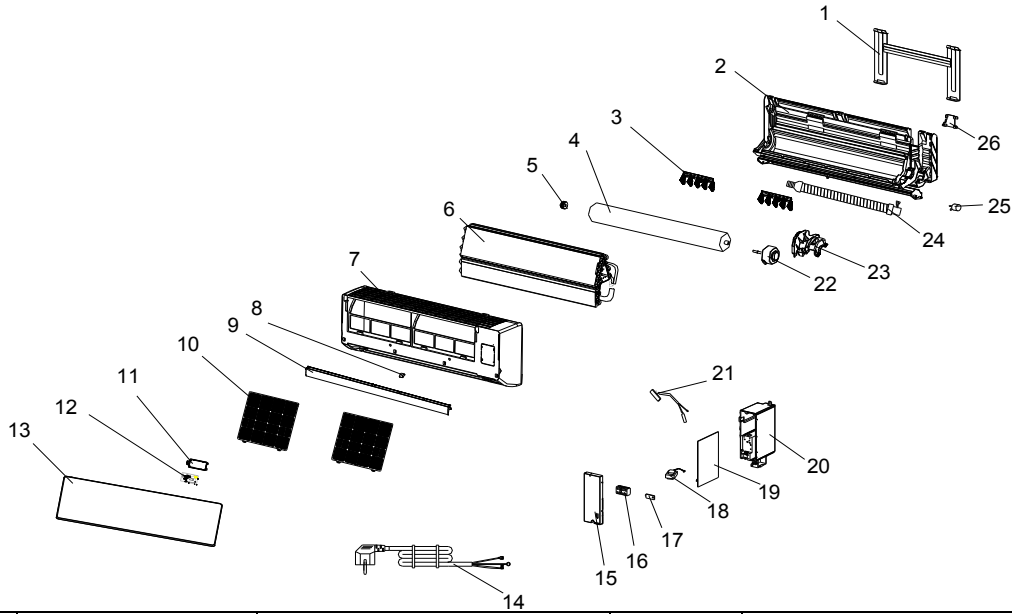

No.	Part No.	Part Name	Q'ty	Remark
1	41109-000042	Installation Plate	1	
2	41199-002755	Base	1	
3	41101-000081	Vertical Vane Assembly	2	
4	42004-000039	Cross Fan	1	
5	42007-000001	Bearing Mount	1	
6	92011-002783	Evaporator	1	
7	41106-002371	Face Frame	1	
8	41108-000066	Screw Cover	1	
9	41103-000101	Vane	1	
10	42008-000037	Air Filter	2	
11	42003-000001	Display PCB Box	1	
12	31102-000085	Display PCB	1	
13	41106-002048	Front Panel	1	
14	22007-000055	Power Supply Cord	1	
15	41201-000068	Electrical Box Cover	1	
16	11304-100023	Terminal	1	
17	42001-000103	Cable Clamp	1	
18	10502-100028	Transformer	1	
19	31101-000562	Main PCB	1	
20	41105-000104	Electrical Box	1	
21	10104-100014	Indoor Sensor Assembly	1	
22	22001-000265	Indoor Motor	1	
23	42003-000060	Indoor Motor Cover	1	
24	42009-000011	Drainage Hose	1	
25	22001-000313	Vane Motor	1	
26	41101-000242	In And Out Pipe Fixer	1	
27	22013-001969	Remote Controller	1	Not shown in Explosion view
28	A1101-007485	Indoor Carton	1	
29	41110-000221	Left Foaming	1	
30	41110-000260	Right Foaming	1	

Outdoor Unit- VAC-12CHSA/XA21 PLUS

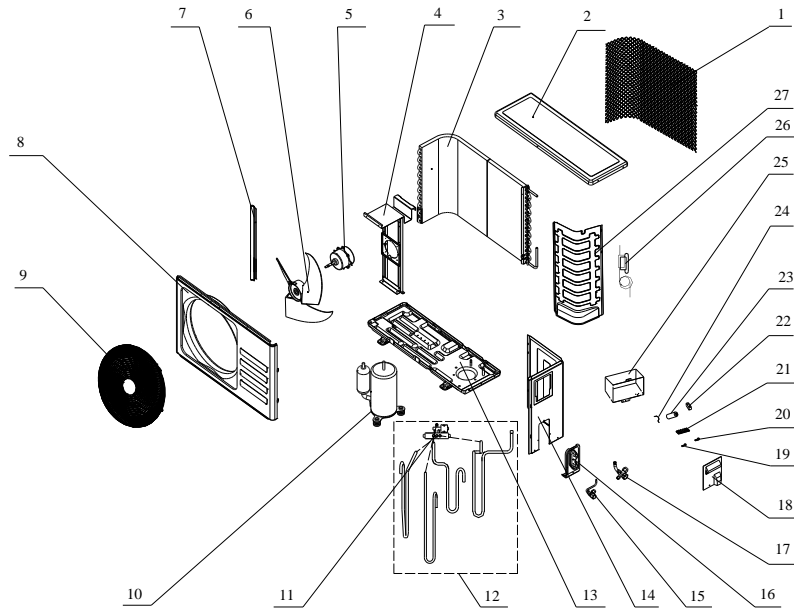

No.	Part No.	Part Name	Q'ty	Remark
1	42011-000109	Grille	1	Optional
2	41207-000014	Top Cover	1	
3	92011-000376	Condenser	1	
4	41203-000037	Outdoor Motor Supporter	1	
5	22001-000009	Outdoor Motor	1	
6	42004-000073	Propeller Fan	1	
7	41205-000124	Left Grille Supporter	1	
8	41206-000038	Front Plate	1	
9	42011-000070	Fan Guard	1	
10	92014-000021	Compressor And It Accessories	1	
11	92008-000177	4-way Valve	1	
12	92007-000817	4-way Valve Assembly	1	
13	41202-000046	Base	1	
14	41205-000054	Right Plate	1	
15	92008-000018	Two-way Valve	1	
16	41204-000010	Valve Supporter	1	
17	92008-000131	Three-way Valve	1	
18	42011-000070	Electrical Box Cover	1	
19	42001-000037	Cable Clamp(φ6)	1	
20	42001-000038	Cable Clamp(φ7)	1	
21	11304-100007	Terminal	1	
22	10303-100015	Fan Motor Capacitor	1	
23	22003-000004	Compressor Capacitor	1	
24	42001-000030	Capacitor Strip	1	
25	41214-000342	Electrical Parts Box	1	
26	92007-001700	Capillary Assembly	1	
27	41208-000121	Partition plate	1	
28	A1401-000012	Base Carton	1	Not shown in Explosion view
29	A1201-008092	Cabinet Carton	1	
30	A1202-000004	Base Foaming	1	
31	A1202-000002	Cover Forming	1	

Indoor Unit- VAC-18CHSA/XA21 PLUS

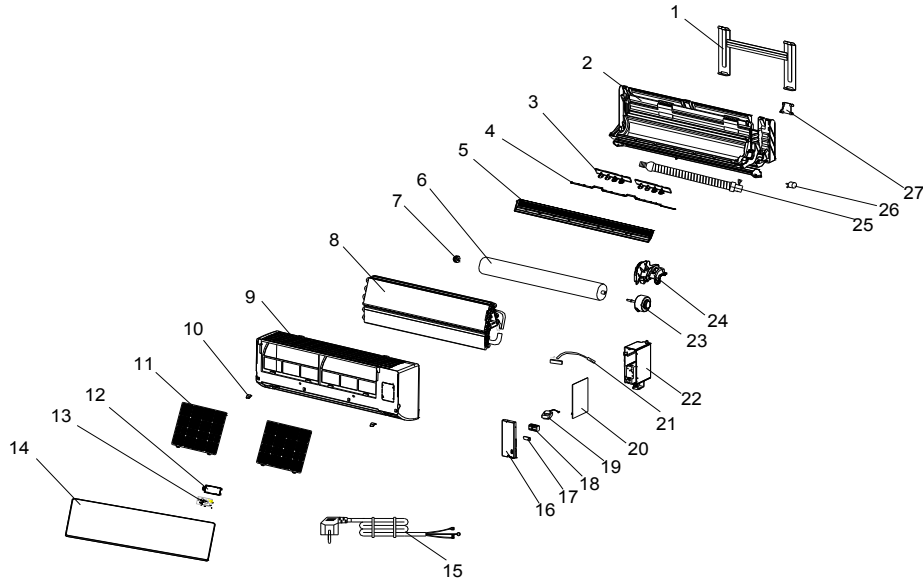

No.	Part No.	Part Name	Q'ty	Remark
1	41109-000041	Installation Plate	1	
2	41102-000041	Base	1	
3	41101-000067	Vertical Vane Assembly	1	
4	41101-000193	Vertical Vane Connector	1	
5	41103-000149	Vane	1	
6	42004-000010	Cross Fan	1	
7	42007-000001	Bearing Mount	1	
8	92011-002773	Evaporator	1	
9	41106-002356	Face Frame	1	
10	41108-000066	Screw Cover	2	
11	42008-000075	Air Filter	1	
12	42003-000001	Display PCB Box	1	
13	31102-000085	Display PCB	1	
14	41106-002078	Front Panel	1	
15	22007-000055	Power Supply Cord	1	
16	41105-000146	Electrical Box Cover	1	
17	42001-000103	Cable Clamp	1	
18	11304-100023	Terminal	1	
19	10502-100028	Transformer	1	
20	31101-000667	Main PCB	1	
21	10104-100014	Indoor Sensor Assembly	1	
22	41105-000104	Electrical Box	1	
23	22001-000268	Indoor Motor	1	
24	41108-000013	Indoor Motor Cover	1	
25	42009-000011	Drainage Hose	1	
26	22001-000321	Vane Motor	1	
27	41101-000242	In And Out Pipe Fixer	1	
28	22013-001969	Remote Controller	1	Not shown in Explosion view
29	A1101-007486	Indoor Carton	1	
30	A2006-000040	Left Foaming	1	
31	A2006-000019	Right Foaming	1	

Outdoor Unit- VAC-18CHSA/XA21 PLUS

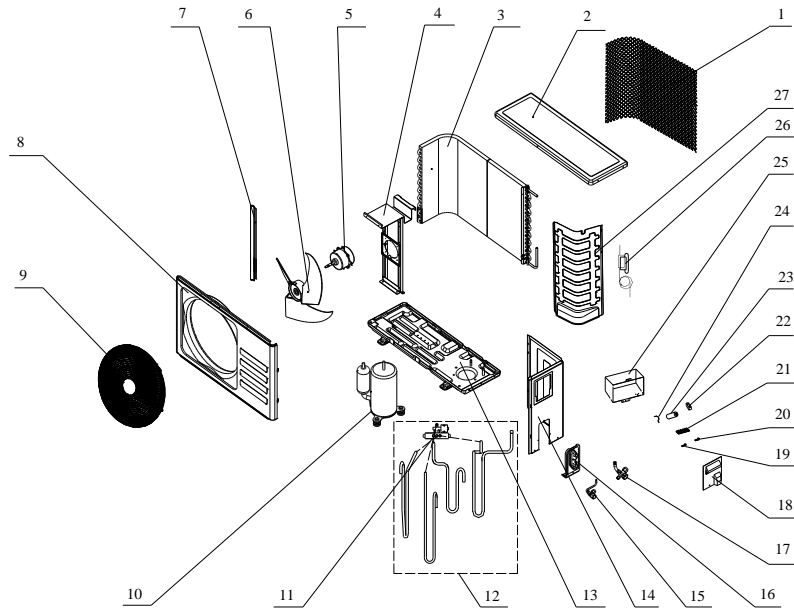

No.	Part No.	Part Name	Q'ty	Remark
1	42011-000110	back Grille	1	Optional
2	41207-000015	Top Cover	1	
3	92011-000162	Condenser	1	
4	41203-000037	Outdoor Motor Supporter	1	
5	22001-000008	Outdoor Motor	1	
6	42004-000083	Propeller Fan	1	
7	41205-000124	Left Grille Supporter	1	
8	41206-000037	Front Plate	1	
9	42011-000070	Fan Guard	1	
10	92014-000584	Compressor	1	
11	92008-000193	4-way Valve	1	
12	92007-005092	4-way Valve Assembly	1	
13	41202-000055	Base	1	
14	41205-000054	Right Plate	1	
15	92008-000018	Two-way Valve	1	
16	41204-000010	Valve Supporter	1	
17	92008-000124	Three-way Valve	1	
18	41201-000005	Electrical Box Cover	1	
19	42001-000037	Cable Clamp(φ6)	1	
20	42001-000038	Cable Clamp(φ10)	1	
21	11304-100007	Terminal	1	
22	10303-100021	Fan Motor Capacitor	1	
23	22003-000004	Compressor Capacitor	1	
24	42001-000030	Capacitor Strip	1	
25	41214-000342	Electrical Parts Box	1	
26	92007-001902	Capillary Assembly	1	
27	41208-000132	Partition plate	1	
28	A1401-000011	Base Carton	1	Not shown in Explosion view.
29	A1201-008094	Cabinet Carton	1	
30	A1202-000005	Base Foaming	1	
31	41213-000006	Cover Forming	1	

Indoor Unit- VAC-24CHSA/XA21 PLUS

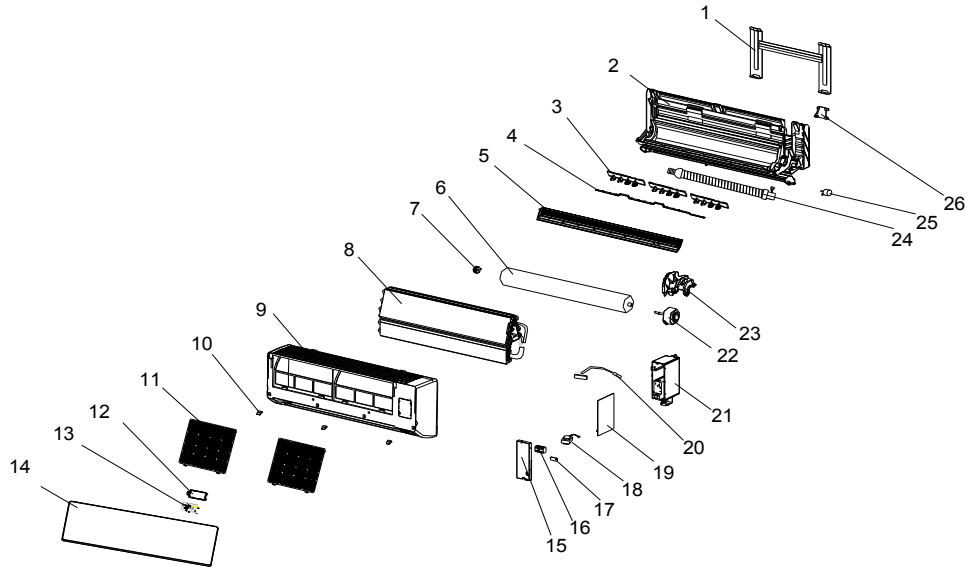

No.	Part No.	Part Name	Q'ty	Remark
1	41109-000019	Installation Plate	1	
2	41102-000016	Base	1	
3	41101-000042	Vertical Vane Assembly	3	
4	41507-000062	Vertical Vane Connector	1	
5	41103-000178	Vane	1	
6	42004-000002	Cross Fan	1	
7	42007-000001	Bearing Mount	1	
8	92011-002761	Evaporator	1	
9	41106-002351	Face Frame	1	
10	41108-000066	Screw Cover	2	
11	42008-000001	Air Filter	2	
12	42003-000001	Display PCB Box	1	
13	31102-000085	Display PCB	1	
14	41106-002088	Front Panel	1	
15	41105-000146	Electrical Box Cover	1	
16	11304-100025	Terminal	1	
17	42001-000103	Cable Clamp	1	
18	10502-100021	Transformer	1	
19	31101-000504	Main PCB	1	
20	10104-100014	Indoor Sensor Assembly	1	
21	41105-000104	Electrical Box	1	
22	22001-000271	Indoor Motor	1	
23	42003-000045	Indoor Motor Cover	1	
24	42009-000011	Drainage Hose	1	
25	22001-000321	Vane Motor	1	
26	41101-000224	In And Out Pipe Fixer	1	
27	22013-001969	Remote Controller	1	Not shown in Explosion view
28	A1101-007487	Indoor Carton	1	
29	A2006-000060	Left Foaming	1	
30	A2006-000059	Right Foaming	1	

Outdoor Unit- VAC-24CHSA/XA21 PLUS

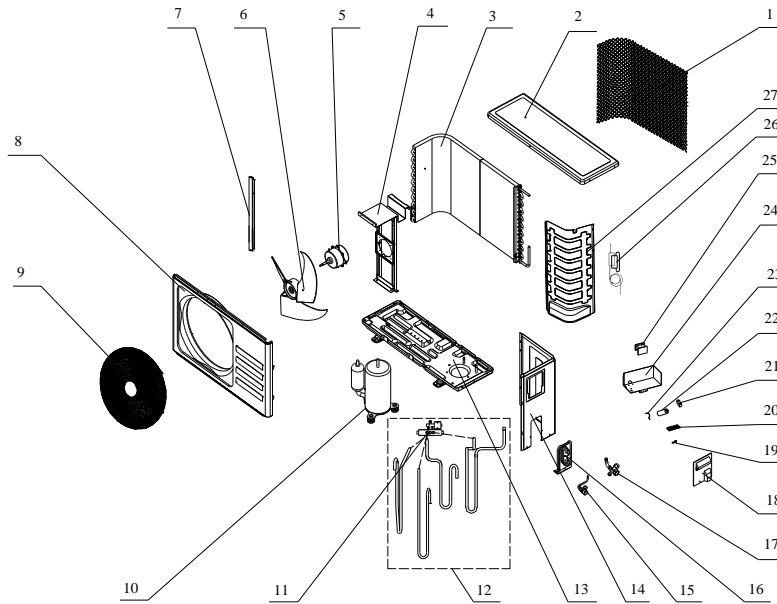

No.	Part No.	Part Name	Q'ty	Remark
1	42011-000111	Grille	1	Optional
2	41207-000018	Top Cover	1	
3	92011-000371	Condenser	1	
4	41203-000039	Outdoor Motor Supporter	1	
5	22001-000018	Outdoor Motor	1	
6	42004-000085	Propeller Fan	1	
7	41205-000127	Left Grille Supporter	1	
8	41206-000039	Front Plate	1	
9	42011-000067	Fan Guard	1	
10	92014-000017	Compressor	1	
11	92008-000180	4-way Valve	1	
12	92007-000796	4-way Valve Assembly	1	
13	41202-000019	Base	1	
14	41205-000057	Right Plate	1	
15	92008-000018	Two-way Valve	1	
16	41204-000013	Valve Supporter	1	
17	92008-000116	Three-way Valve	1	
18	41201-000005	Electrical Box Cover	1	
19	42001-000106	Cable Clamp	1	
20	11304-100010	Terminal	1	
21	10303-100017	Fan Motor Capacitor	1	
22	22003-000006	Compressor Capacitor	1	
23	42001-000030	Capacitor Strip	1	
24	41211-000084	Electrical Parts Box	1	
25	22008-000003	AC Contactor	1	
26	92007-001879	Capillary Assembly	1	
27	41208-000119	Partition plate	1	
28	A1201-008097	Cabinet Carton	1	Not show in explosion View
29	41213-000005	Upper Cover	1	
30	A1202-000011	Lower Foaming	1	
31	A2005-000487	Base Carton	1	

7. Precaution

7.1 SAFETY RULES AND RECOMMENDATIONS FOR THE INSTALLATION

- Read this guide before installing and using the appliance.
- During the installation of the indoor and outdoor units the access to the working area should be forbidden to children.
Unforeseeable accidents could happen.
- Make sure that the base of the outdoor unit is firmly fixed.
- Check that air cannot enter the refrigerant system and check for refrigerant leaks when moving the air conditioner.
- Check that air cannot enter the refrigerant system and check for refrigerant leaks when moving the air conditioner.
- The ratings of the fuse installed in the built in-control unit are T 5A / 250V.
- The user must protect the indoor unit with a fuse of suitable capacity for the maximum input current or with another overload protection device.
- Ensure that the mains voltage corresponds to that stamped on the rating plate. Keep the switch or power plug clean. Insert the power plug correctly and firmly into the socket, thereby avoiding the risk of electric shock or fire due to insufficient contact.
- Check that the socket is suitable for the plug, otherwise have the socket changed.
- The appliance must be fitted with means for disconnection from the supply mains having a contact separation in all poles that provide full disconnection under over voltage category III conditions, and these means must be incorporated in the fixed wiring in accordance with the wiring rules.
- The air conditioner must be installed by professional or qualified persons. Do not install the appliance at a distance of less than 50 cm from inflammable substances (alcohol, etc.) Or from pressurized containers (e.g. spray cans).
- If the appliance is used in areas without the possibility of ventilation, precautions must be taken to prevent any leaks of refrigerant gas from remaining in the environment and creating a danger of fire.
- The packaging materials are recyclable and should be disposed of in the separate waste bins. Take the air conditioner at the end of its useful life to a special waste collection center for disposal.
- Only use the air conditioner as instructed in this booklet. These instructions are not intended to cover every possible condition and situation. As with any electrical household appliance, common sense and caution are therefore always recommended for installation, operation and maintenance.
- The appliance must be installed in accordance with applicable national regulations.
- Before accessing the terminals, all the power circuits must be disconnected from the power supply.
- The appliance shall be installed in accordance with national wiring regulations.
This appliance can be used by children aged from 8 years and above and persons with reduced physical, sensory or mental capabilities or lack of experience and knowledge if they have been given supervision or instruction concerning use of the appliance in a safe way and understand the hazards involved. Children shall not play with the appliance. Cleaning and user maintenance shall not be made by children without supervision.

7.2 SAFETY RULES AND RECOMMENDATIONS FOR THE USER

- Do not try to install the conditioner alone; always contact specialized technical personnel. Cleaning and maintenance must be carried out by specialized technical personnel. In any case disconnect the appliance from the mains electricity supply before carrying out any cleaning or maintenance.
- Ensure that the mains voltage corresponds to that stamped on the rating plate. Keep the switch or power plug clean. Insert the power plug correctly and firmly into the socket, thereby avoiding the risk of electric shock or fire due to insufficient contact.
- Do not pull out the plug to switch off the appliance when it is in operation, since this could create a spark and cause a fire, etc.
- This appliance has been made for air conditioning domestic environments and must not be used for any other purpose, such as for drying clothes, cooling food, etc.
- The packaging materials are recyclable and should be disposed of in the separate waste bins. Take the air conditioner at the end of its useful life to a special waste collection center for disposal.
- Always use the appliance with the air filter mounted. The use of the conditioner without air filter could cause an excessive accumulation of dust or waste on the inner parts of the device with possible subsequent failures.
- The user is responsible for having the appliance installed by a qualified technician, who must check that it is earthed in accordance with current legislation and insert a thermomagnetic circuit breaker.
- The batteries in remote controller must be recycled or disposed of properly. Disposal of Scrap Batteries.
--- Please discard the batteries as sorted municipal waste at the accessible collection point.
- Never remain directly exposed to the flow of cold air for a long time. The direct and prolonged exposition to cold air could be dangerous for your health. Particular care should be taken in the rooms where there are children, old or sick people.
- If the appliance gives off smoke or there is a smell of burning, immediately cut off the power supply and contact the Service Centre.
- The prolonged use of the device in such conditions could cause fire or electrocution.
- Have repairs carried out only by an authoritative Service Centre of the manufacturer. Incorrect repair could expose the user to the risk of electric shock, etc.
- Unhook the automatic switch if you foresee not to use the device for a long time. The airflow direction must be properly adjusted.
- The flaps must be directed downwards in the heating mode and upwards in the cooling mode. Only use the air conditioner as instructed in this booklet. These instructions are not intended to cover every possible condition and situation. As with any electrical household appliance, common sense and caution are therefore always recommended for installation, operation and maintenance.

8. Names of parts

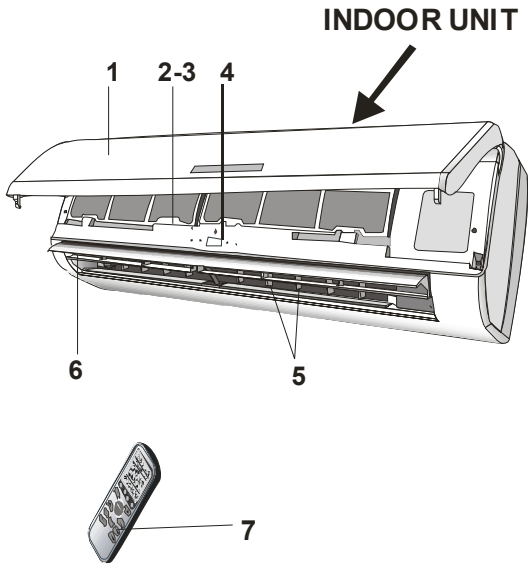

Indoor unit	
No.	Name
1	Front panel
2	Air filter
3	Special filter(option)
4	Display PCB
5	Vertical vane
6	Horizontal vane
7	Remote controller

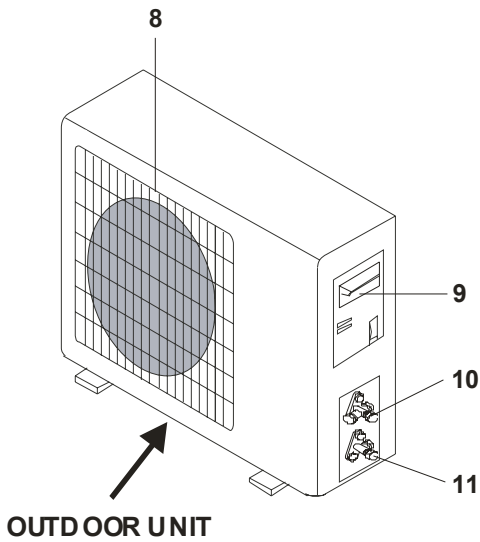

Outdoor unit	
No.	Name
8	Air outlet grille
9	Electronic box cover
10	2-way valve
11	3-way valve

9. Installation manual

9.1 Installation Details

Connecting pipe length

Model	Pipe size(Inch)	
	Liquid	Gas
VAC-09CHSA/XA21 PLUS	1/4	3/8
VAC-12CHSA/XA21 PLUS	1/4	3/8
VAC-18CHSA/XA21 PLUS	1/4	1/2
VAC-24CHSA/XA21 PLUS	1/4	5/8

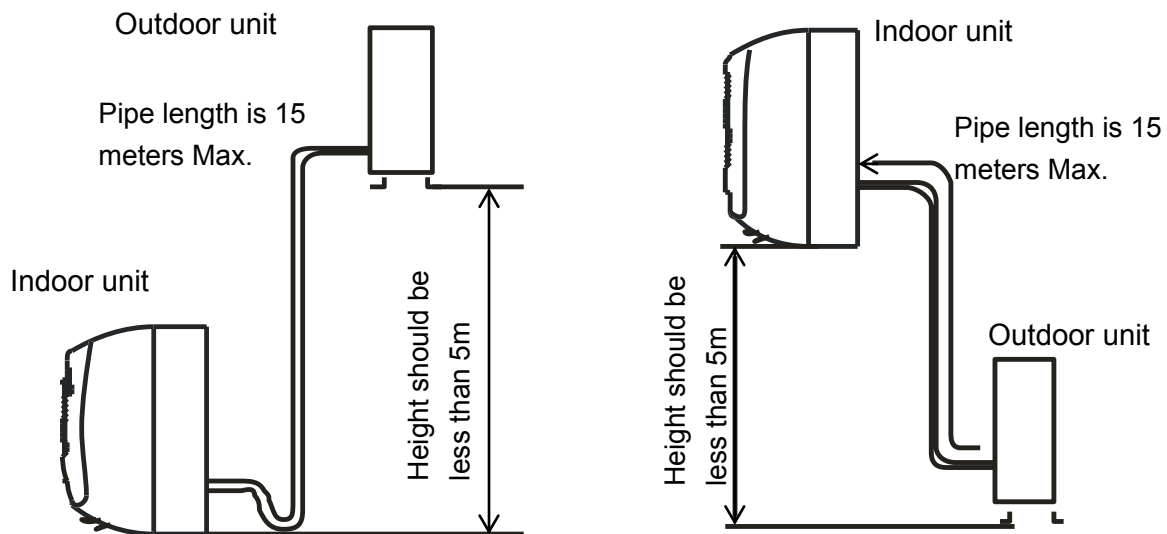

Mode	Standard length: m	Refrigerant piping Max. length: m A	Additional refrigerant B Calculation: $\times g = Bg/m(A-5m)$
VAC-09CHSA/XA21 PLUS	3.0	25	20g/m
VAC-12CHSA/XA21 PLUS	3.5	25	20g/m
VAC-18CHSA/XA21 PLUS	5.0	25	30g/m
VAC-24CHSA/XA21 PLUS	5.0	25	30g/m

Connecting cables

The power cord should be selected according to the following specifications sheet.

Appliance Amps	Wire Size
5	AWG21/0.75 mm ²
10	AWG18/1.0 mm ²
13	AWG15 /1. 5 mm ²
18	AWG14/1.6 mm ²
25	AWG12/2.0 mm ²
30	AWG10/2.5 mm ²

9.2 Installation for the first time

Indoor unit

- Install the indoor unit level on a strong wall that is not subject to vibrations
- The inlet and outlet ports should not be obstructed: the air should be able to blow all over the room.
- Do not install the unit near a source of heat, steam, or flammable gas.
- Install the unit near an electric socket or private circuit.
- Do not install the unit where it will be exposed to direct sunlight.
- Install the unit where connection between indoor and outdoor unit is as easy as possible.
- Install the unit where it is easy to drain the condensed water.
- Check the machine operation regularly and leave the necessary spaces as shown in the picture.
- Install the indoor unit where the filter can be easily accessible.

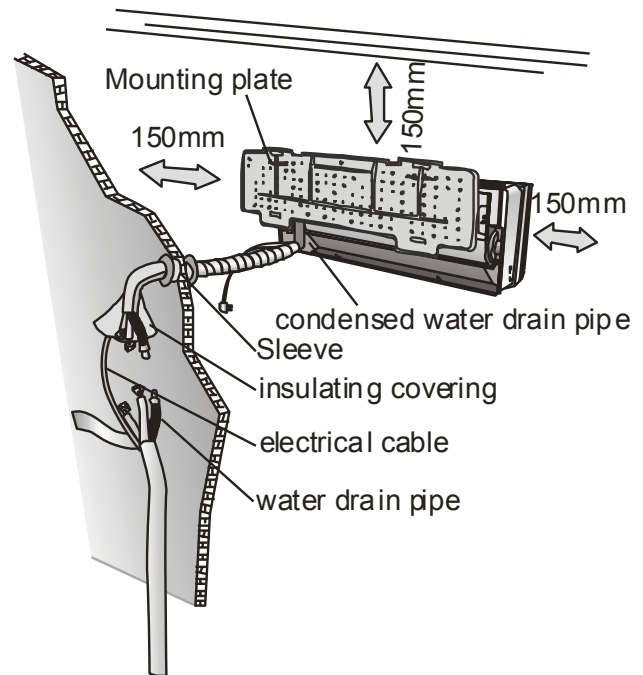

OUTDOOR UNIT

- Do not install the outdoor unit near sources of heat, steam or flammable gas.
- Do not install the unit in too windy or dusty places.
- Do not install the unit where people often pass. Select a place where the air discharge and operating sound level will not disturb the neighbours.
- Avoid installing the unit where it will be exposed to direct sunlight (other wise use a protection, if necessary, that should not interfere with the air flow).
- Leave the spaces as shown in the picture for
- The air to circulate freely.
- Install the outdoor unit in a safe and solid place.
- If the outdoor unit is subject to vibration, place rubber gaskets onto the feet of the unit.
- Install the indoor unit in the room to be air conditioning, avoiding to installation in corridors or communal areas.

Minimum space to be left (mm) showing in the picture.

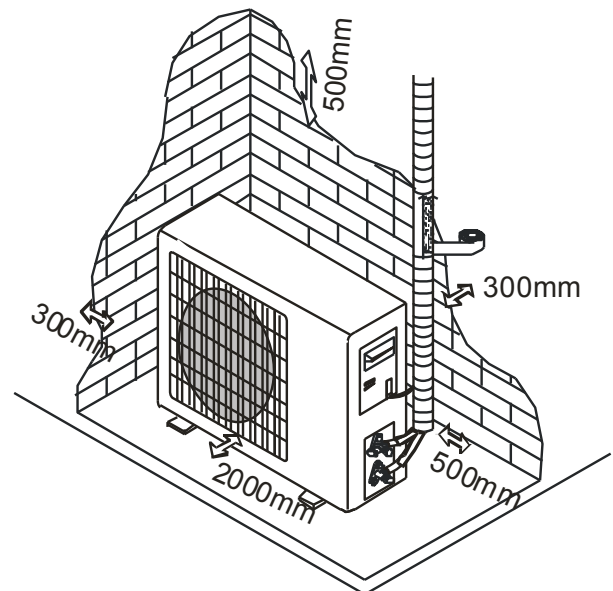

- Install the indoor unit in the room to be air conditioning, avoiding to installation in corridors or communal areas.
- Install the indoor unit at a height of at least 2.5m from the ground.

To install, proceed as follows:

9.2.1 Installation of the mounting plate.

- 1) By using a level, put the mounting plate in a perfect square position vertically and horizontally.
- 2) Drill 32mm deep holes in the wall to fix the plate.
- 3) Insert the plastic anchors into the hole.
- 4) Fix the mounting plate by using the provided tapping screws.
- 5) Check that the mounting plate is correctly fixed.

Note: The shape of the mounting plate may be different from the one above, but installation method is similar.

9.2.2 Drilling a hole in the wall for the piping

- 1) Decide where to drill the hole in the wall for the piping (if necessary) according to the position of the mounting plate
- 2) Install a flexible flange through the hole in the wall to keep the latter intact and clean.

The hole must slope downwards towards the exterior.

Note: Keep the drain pipe down towards the direction of the wall hole, otherwise leakage may occur.

9.2.3 Electrical connections---Indoor unit

- 1).Lift the front panel.
- 2).Take off the cover as indicated in the picture (by removing a screw or by breaking the hooks).
- 3).For the electrical connections, see the circuit diagram on the right part of the unit under the front panel.
- 4).Connect the cable wires to the screw terminals by following the numbering, Use wire size suitable to the electric power input (see name plate on the unit) and according to all current national safety code requirements.
- 5).The cable connecting the outdoor and indoor units must be suitable for outdoor use.

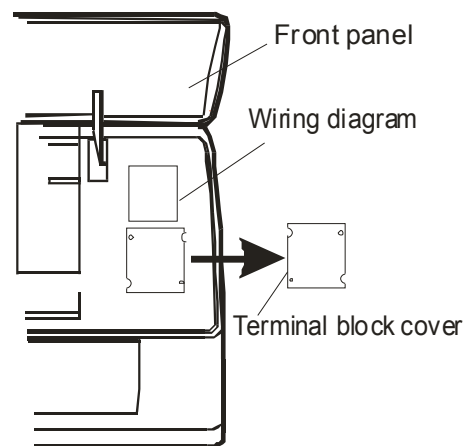
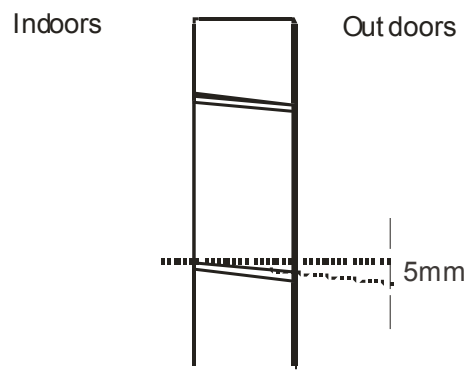
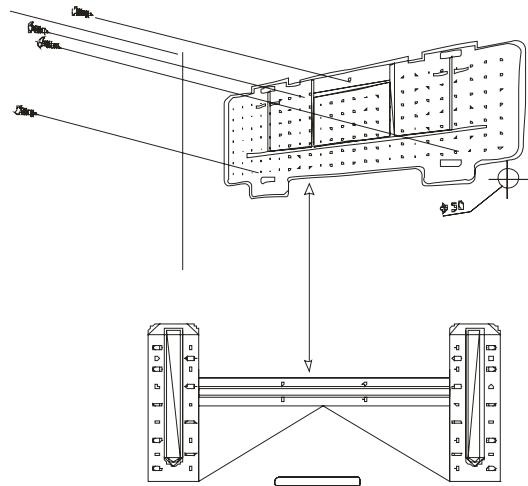

- 6).The plug must be accessible also after the appliance has been installed so that it can be pulled out if necessary.
- 7).An efficient earth connection must be ensured.
- 8).If the power cable is damaged, it must be replaced by an authorized Service Centre.

9.2.4 Refrigerant piping connection

The piping can be run in the 3 directions indicated by numbers in the picture. When the piping is run in direction 1 or 3, cut a notch along the groove on the side of the indoor unit with a cutter.

Run the piping in the direction of the wall hole and bind the copper pipes, the drain pipe and the power cables together with the tape with the drain pipe at the bottom, so that water can flow freely.

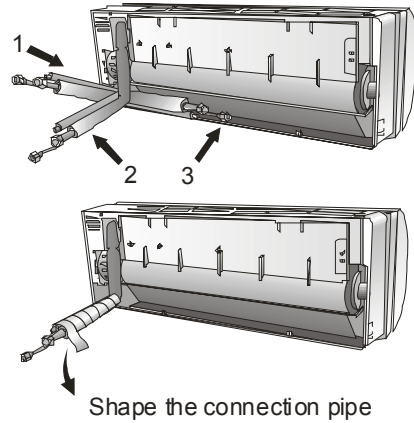

9.2.5 Connecting the pipes.

- Do not remove the cap from the pipe until connecting it, to avoid dampness or dirt from entering.
- If the pipe is bent or pulled too often, it will become stiff. Do not bend the pipe more than three times at one point.
- When extending the rolled pipe, straighten the pipe by unwinding it gently as shown in the picture.

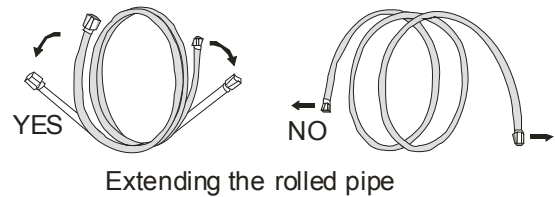

9.2.6 Connections to the indoor unit

- 1).Remove the indoor unit pipe cap (check that there is no debris inside).
- 2).Insert the flare nut and create a flange at the extreme end of the connection pipe.
- 3).Tighten the connections by using two wrenches working in opposite directions.

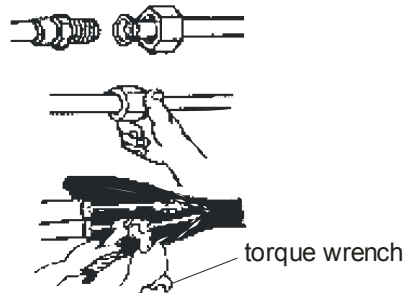

9.2.7 Indoor unit condensed water drainage

The indoor unit condensed water drainage is fundamental for the success of the installation.

- 1).Place the drain hose below the piping, taking care not to create siphons.
- 2).The drain hose must slant downwards to aid drainage.
- 3).Do not bend the drain hose or leave it protruding or twisted and do not put the end of it in water. If an extension is connected to the drain hose, ensure that it is lagged when it passes into the indoor unit.

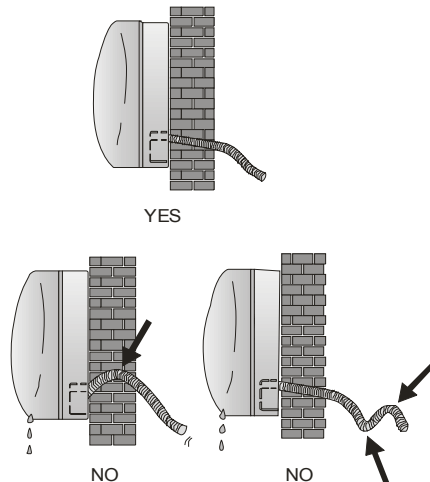

4).If the piping is installed to the right, the pipes, power cable and drain hose must be lagged and secured onto the rear of the unit with a pipe connection.

- Insert the pipe connection into the relative slot.
- Press to join the pipe connection to the base.

9.2.8 Electronic connections

1. Take the cover away.
2. Connect the cable wires to the terminal board using the same numbering as in the indoor unit.
3. For the electrical connections, see the wiring diagram on the back of the cover
4. Fasten the cables with a cable-clamp.
5. An efficient earth connection must be ensured.
6. Replace the covers.

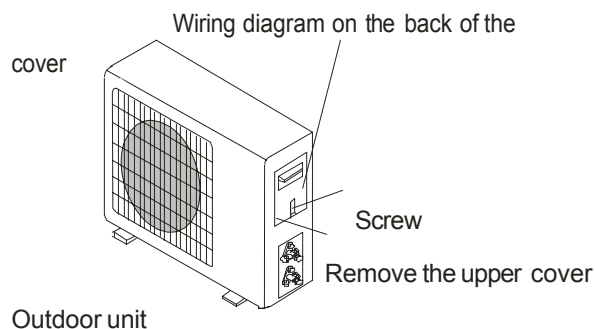

9.2.9 Connecting the pipe

Screw the flare nuts to the outdoor unit coupling with the same tightening procedures described for the indoor unit.

Note: If the tightening torque is not sufficient, there will probably be some leakage. With excessive tightening torque there will also be some leakage, as the flange could be damaged.

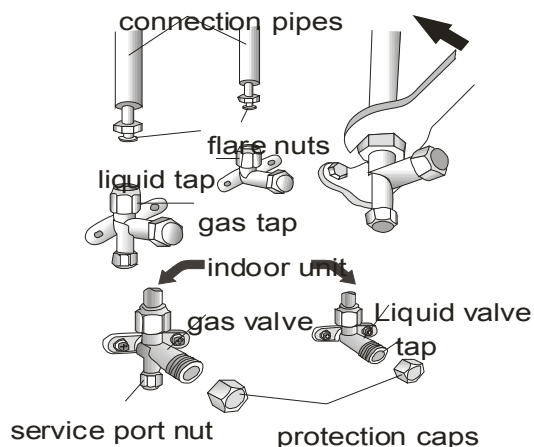

9.2.10 Bbeding

Air and humidity left inside the refrigerant circuit can cause compressor malfunction. After having connected the indoor and outdoor units, bleed the air and humidity from the refrigerant circuit by using a vacuum pump.

The air and humidity left inside the refrigerant circulation can cause compressor malfunction. After having connected the indoor and outdoor units, bleed the air and humidity from the refrigerant circulation using a vacuum pump.

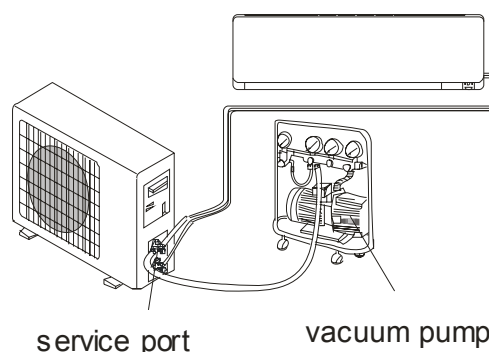

10. Trouble shooting

10.1 Product does not operate at all.

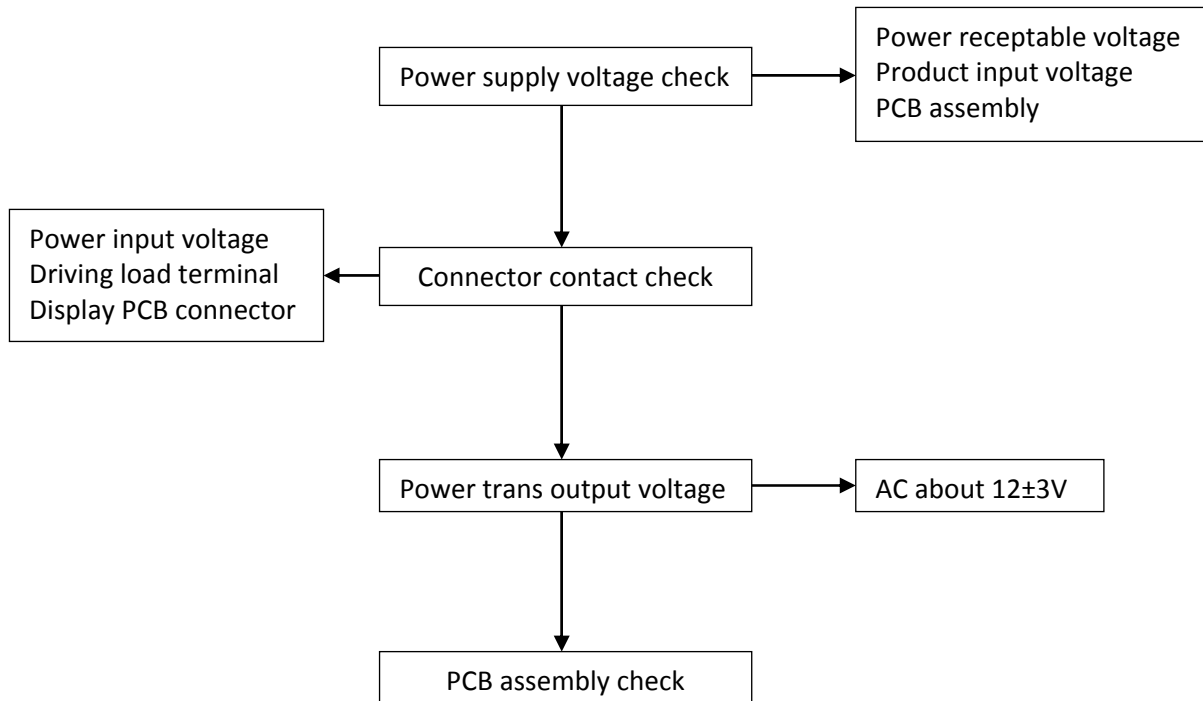

10.2 Sensor failure (E1, E2).

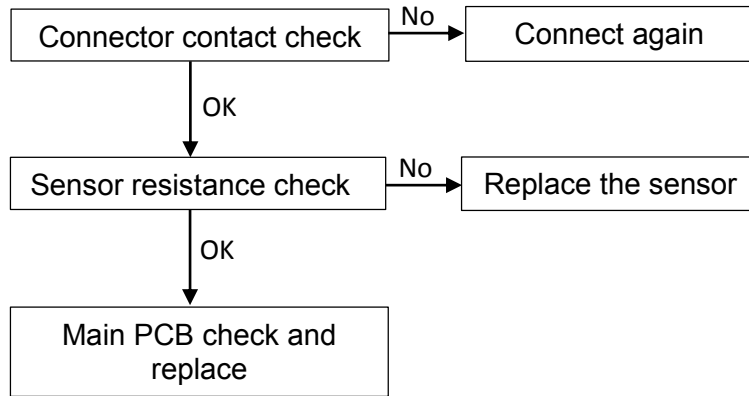

10.3 Indoor fan does not operate at all (E6).

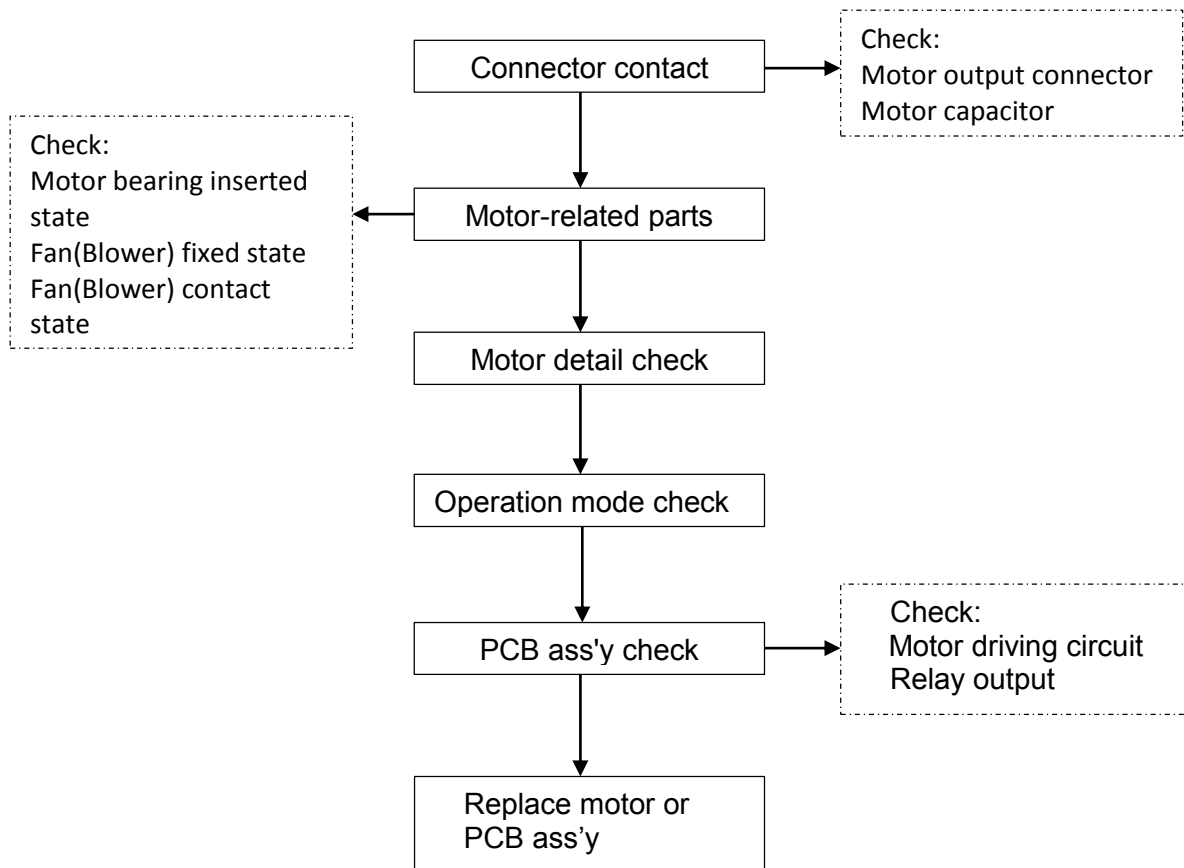

10.4 System protection (E4)

When the unit operation, after 5 minutes, the system will check the temperature of the pipe, if the temperature is at least 2 °C less than before operation the system is normal, otherwise Freon short of system and display E4.

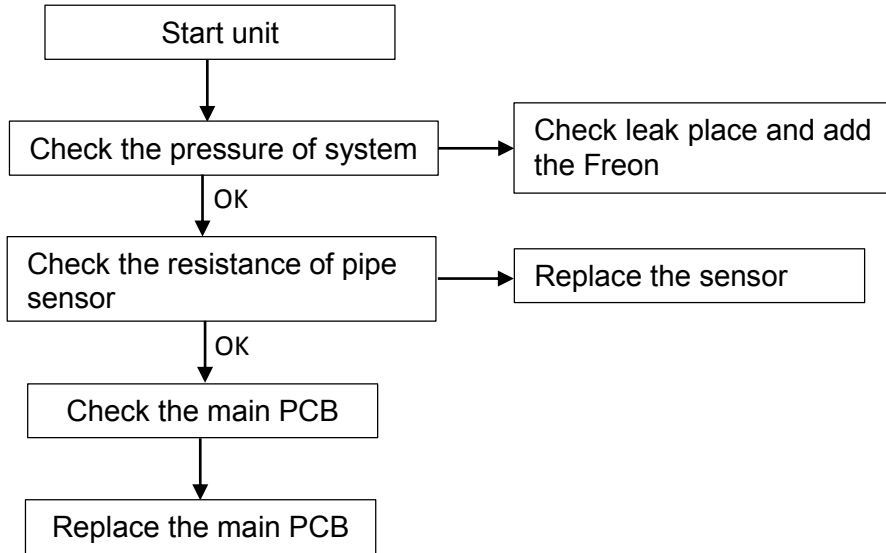

10.5 System protection (E5) (High/low pressure protection model)

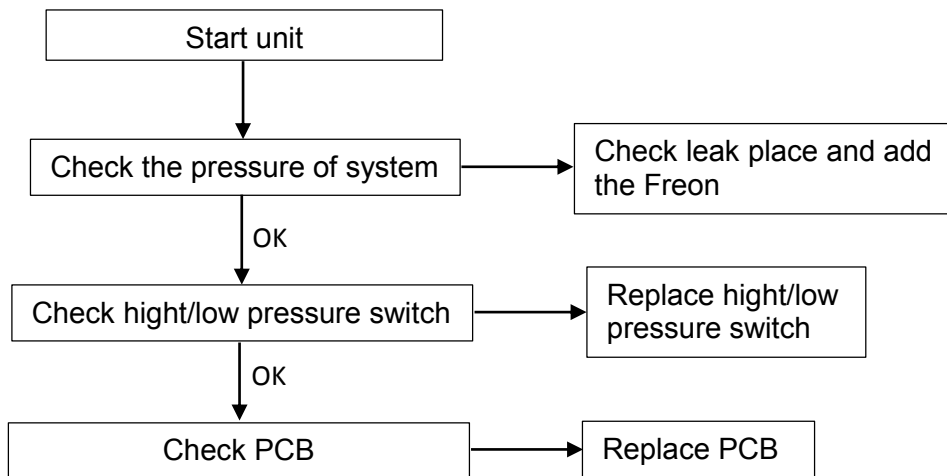

10.6 Compressor or outdoor fan does not operate at all.

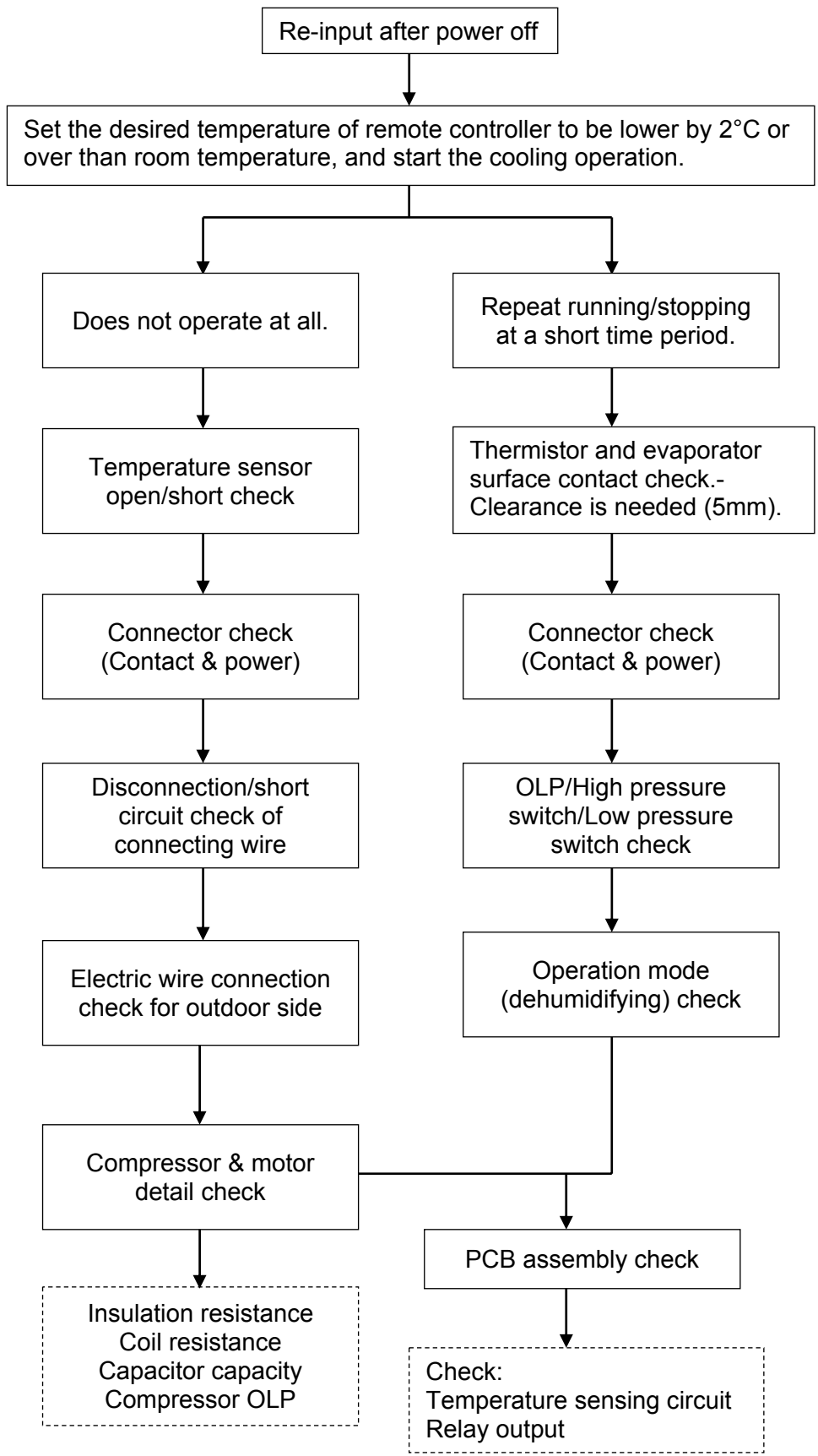

10.7 Vane does not operate at all.

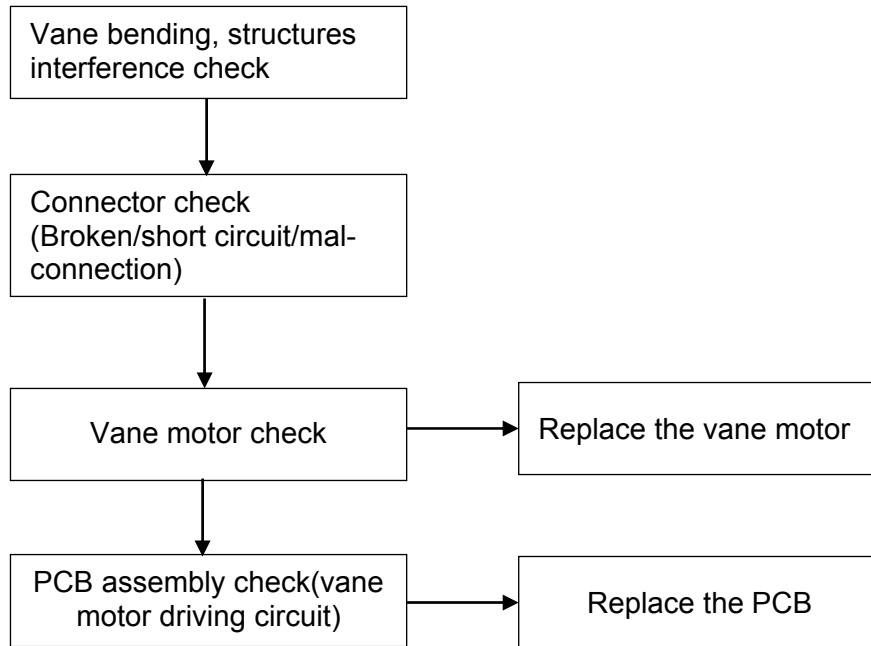

10.8 Cooling/heating conversion is disable.

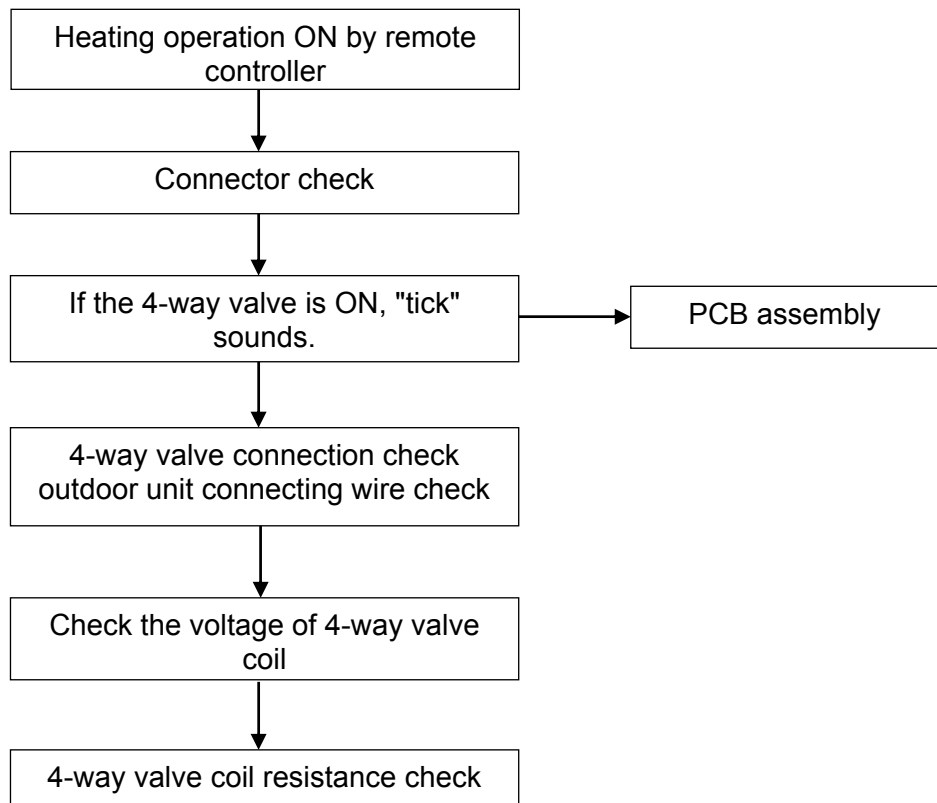

10.9 Examples of repairing

10.9.1 Display E1 or E2

Reasons:

- 1) The sensor connection terminal loose or not plugged in.

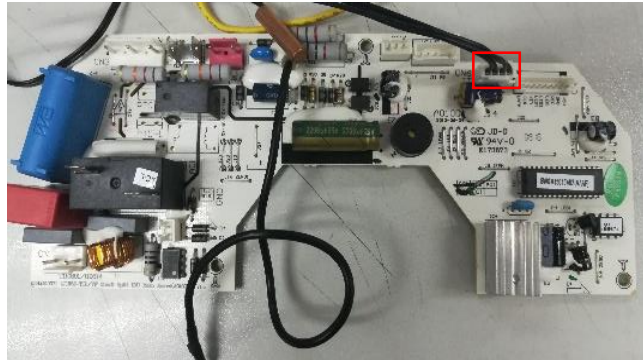
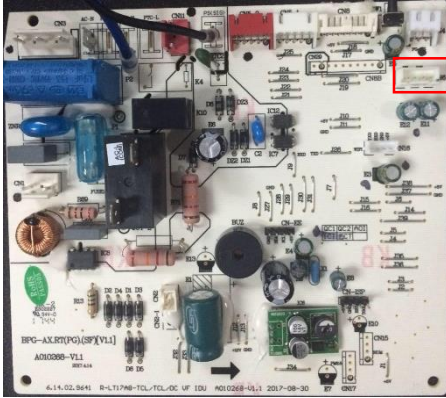

Solution: Check the connector of sensor and slot (CN6), if loose or not plugged in, please connect again.

- 2) Room temperature sensor (IRT) and Indoor pipe (coil) temperature sensor (IPT) damage (short or broken).

Solution: check the resistance of the sensor $R(25^{\circ}\text{C}) = 5\text{ k}\Omega$, if short or broken please replace it.

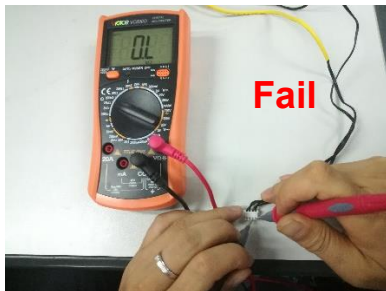

- 3) The PCB fail.

Solution: Replace the indoor main PCB.

10.9.2 Display E6

Reasons:

- 1) The indoor motor connection terminal loose or not plugged in.

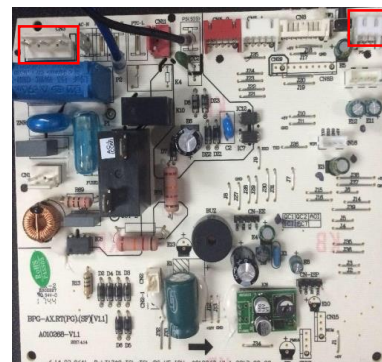
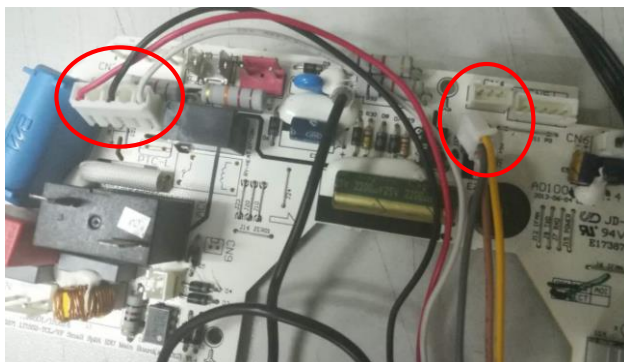

Solution: Check the connector of indoor motor and slot (CN3) and (CN4), if loose or not plugged in, please connect again.

2) The indoor motor damage.

Solution: Check and replace the motor.

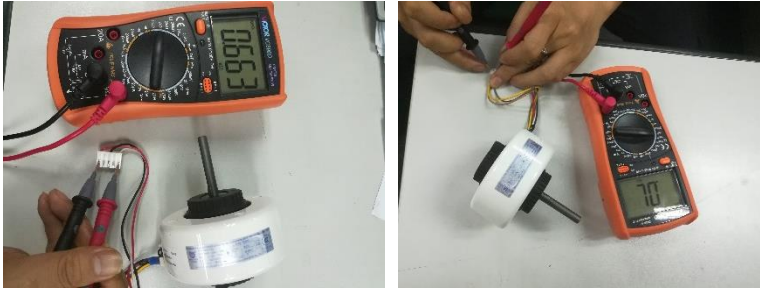

3) The indoor main PCB damage.

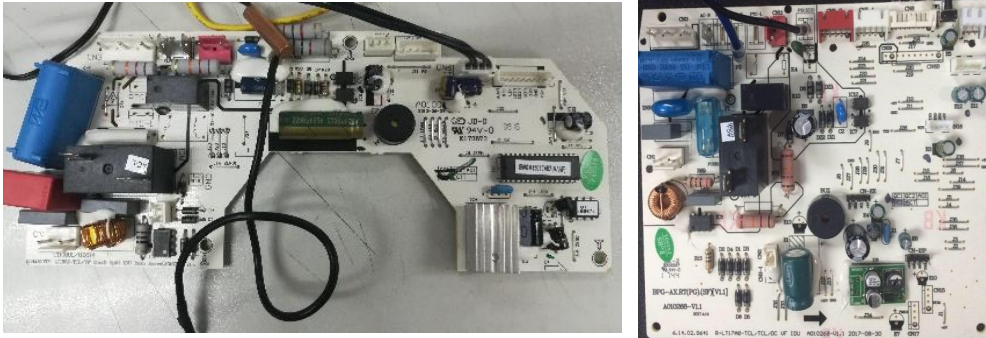

Solution: Replace the indoor main PCB.

10.10 THERMISTOR TEMPERATURE CHARACTERISTICS

Indoor unit room temperature and pipe temperature characteristics

TEMP. (°C)	Resistance (k Ohm)	Voltage of resistance	TEMP. (°C)	Resistance (k Ohm)	Voltage of resistance	TEMP. (°C)	Resistance (k Ohm)	Voltage of resistance
-30	63.513	4.628	15	7.447	2.968	60	1.464	1.115
-29	60.135	4.609	16	7.148	2.918	61	1.418	1.088
-28	56.956	4.589	17	6.863	2.868	62	1.374	1.061
-27	53.963	4.568	18	6.591	2.819	63	1.331	1.035
-26	51.144	4.547	19	6.332	2.769	64	1.290	1.009
-25	48.488	4.524	20	6.084	2.720	65	1.250	0.984
-24	45.985	4.501	21	5.847	2.671	66	1.212	0.960
-23	43.627	4.477	22	5.621	2.621	67	1.175	0.936
-22	41.403	4.452	23	5.404	2.572	68	1.139	0.913
-21	39.305	4.426	24	5.198	2.524	69	1.105	0.890
-20	37.326	4.399	25	5.000	2.475	70	1.072	0.868
-19	35.458	4.371	26	4.811	2.427	71	1.040	0.847
-18	33.695	4.343	27	4.630	2.379	72	1.009	0.825
-17	32.030	4.313	28	4.457	2.332	73	0.979	0.805
-16	30.458	4.283	29	4.292	2.285	74	0.950	0.785
-15	28.972	4.252	30	4.133	2.238	75	0.922	0.765
-14	27.567	4.219	31	3.981	2.192	76	0.895	0.746
-13	26.239	4.186	32	3.836	2.146	77	0.869	0.728
-12	24.984	4.152	33	3.697	2.101	78	0.843	0.710
-11	23.795	4.117	34	3.563	2.057	79	0.819	0.692
-10	22.671	4.082	35	3.435	2.012	80	0.795	0.675
-9	21.606	4.045	36	3.313	1.969	81	0.773	0.658
-8	20.598	4.008	37	3.195	1.926	82	0.751	0.641
-7	19.644	3.969	38	3.082	1.883	83	0.729	0.625
-6	18.732	3.930	39	2.974	1.842	84	0.709	0.610
-5	17.881	3.890	40	2.870	1.800	85	0.689	0.595
-4	17.068	3.850	41	2.770	1.760	86	0.669	0.580
-3	16.297	3.808	42	2.674	1.720	87	0.651	0.566
-2	15.565	3.766	43	2.583	1.681	88	0.633	0.552
-1	14.871	3.723	44	2.494	1.642	89	0.615	0.538
0	14.212	3.680	45	2.410	1.604	90	0.598	0.525
1	13.586	3.635	46	2.328	1.567	91	0.582	0.512
2	12.991	3.590	47	2.250	1.530	92	0.566	0.499
3	12.426	3.545	48	2.174	1.495	93	0.550	0.487
4	11.889	3.499	49	2.102	1.459	94	0.535	0.475
5	11.378	3.452	50	2.032	1.425	95	0.521	0.463
6	10.893	3.406	51	1.965	1.391	96	0.507	0.452
7	10.431	3.358	52	1.901	1.357	97	0.493	0.441
8	9.991	3.310	53	1.839	1.325	98	0.480	0.430
9	9.573	3.262	54	1.779	1.293	99	0.467	0.419
10	9.174	3.214	55	1.721	1.262	100	0.455	0.409
11	8.795	3.165	56	1.666	1.231			
12	8.433	3.116	57	1.613	1.201			
13	8.089	3.067	58	1.561	1.172			
14	7.760	3.017	59	1.512	1.143			

Resistance at 25°C : 5 kΩ.

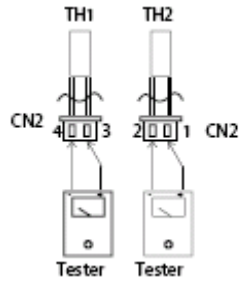

TH1: indoor room temperature sensor and outside air temperature sensor

TH2: indoor exchange temperature sensor and outside exchange temperature sensor

Before measuring resistance, disconnect connectors as shown above.